

零件样本

Notes for using this parts book

目 录

CONTENTS

A. 主轴部件/Machine body.....	1
B. 上轴部件/Upper shaft mechanism.....	1
C. 针杆部件/Needle bar mechanism.....	3
D1.抬压脚部件（9270）/Presser bar mechanism(9270).....	3
D2.抬压脚部件（9280）/Presser bar mechanism(9280).....	5
E. 带轮部件/Pulley mechanism	5
F. 送料部件/Feed mechanism.....	7
G1.零件关系（9270）/Gauge Parts(9270 Standard).....	9
G2.零件关系（9280）/Gauge parts(9280 Standard).....	9
J. 下轴部件/Lower shaft mechanism.....	11
K. 弯针轴部件/Looper mechanism.....	13
L1. 上线过线部件（9270）/Upper threading mechanism(9270).....	15
L2. 上线过线部件（9280）/Upper threading mechanism(9280).....	17
M1. 下线过线部件（9270）/Lower threading mechanism(9270).....	19
M2. 下线过线部件（9280）/Lower threading mechanism(9280).....	23
2PL/PL 专用部件/Special components for 2PL/PL.....	27
PS 专用件/Spscial components for PS.....	29
Z1.附件/Accessories.....	31
不同型号的零件清单/Different parts list.....	33

A. 主体部件/Machine body

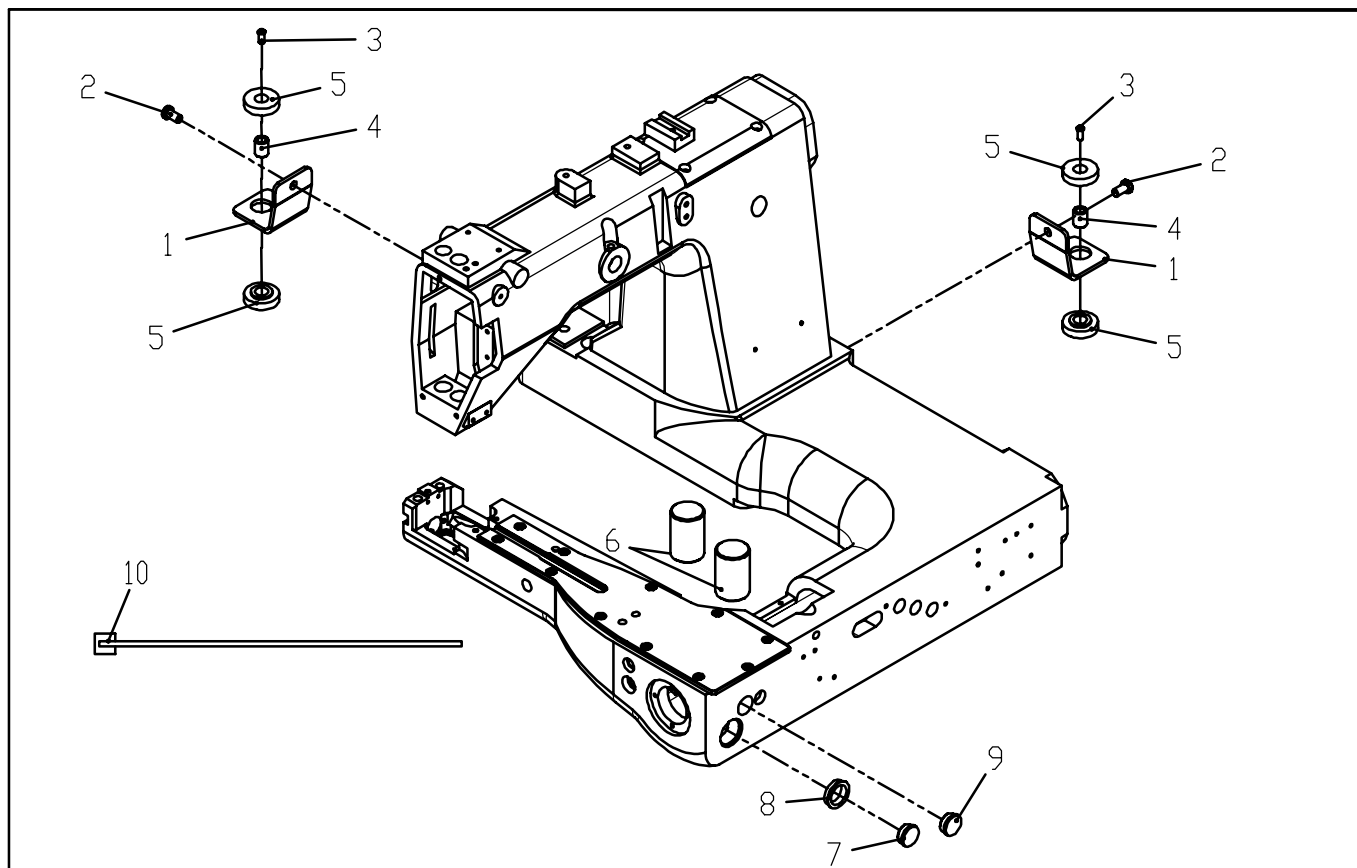

B. 上轴部件/Upper shaft mechanism

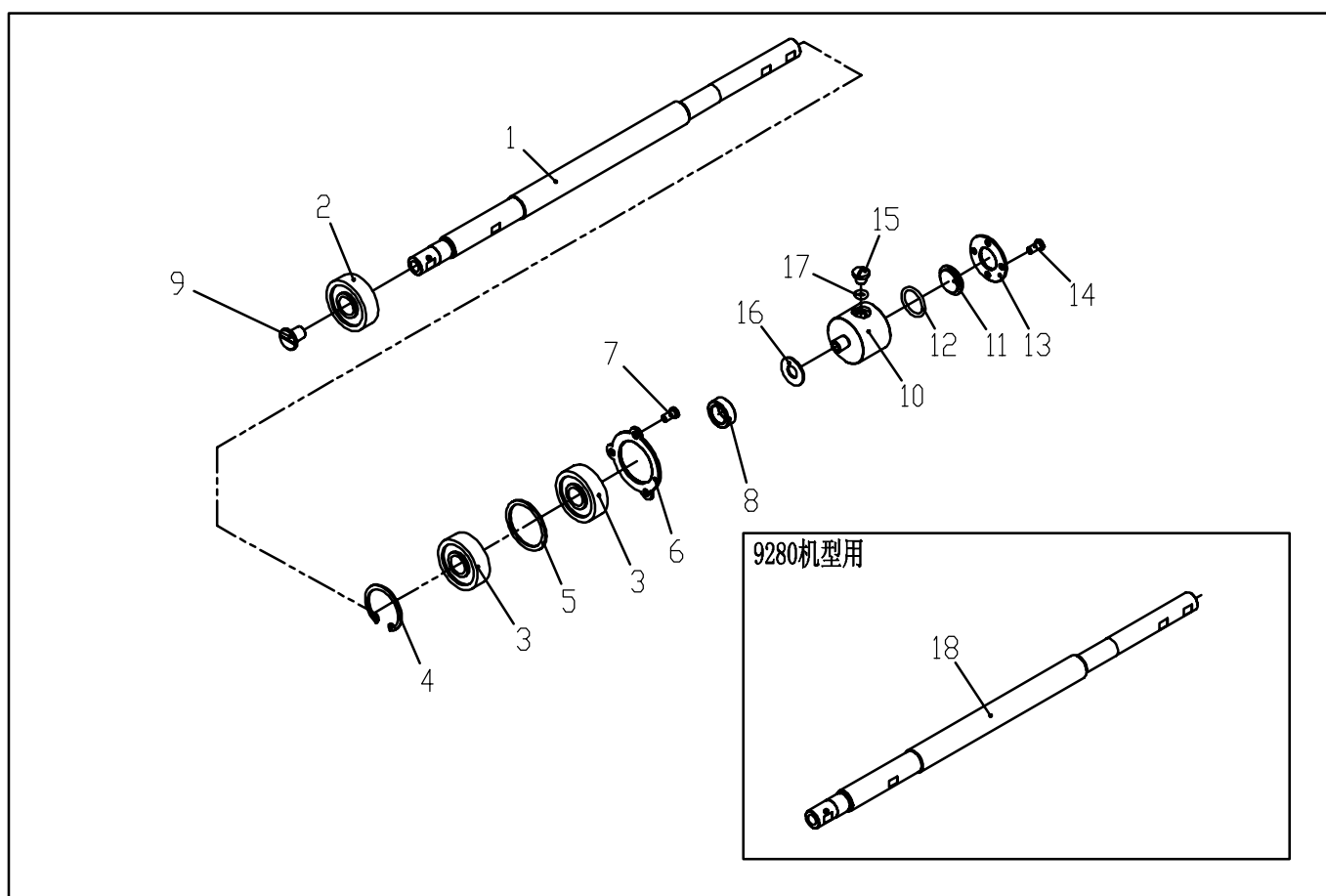

C. 针杆部件/Needle bar mechanism

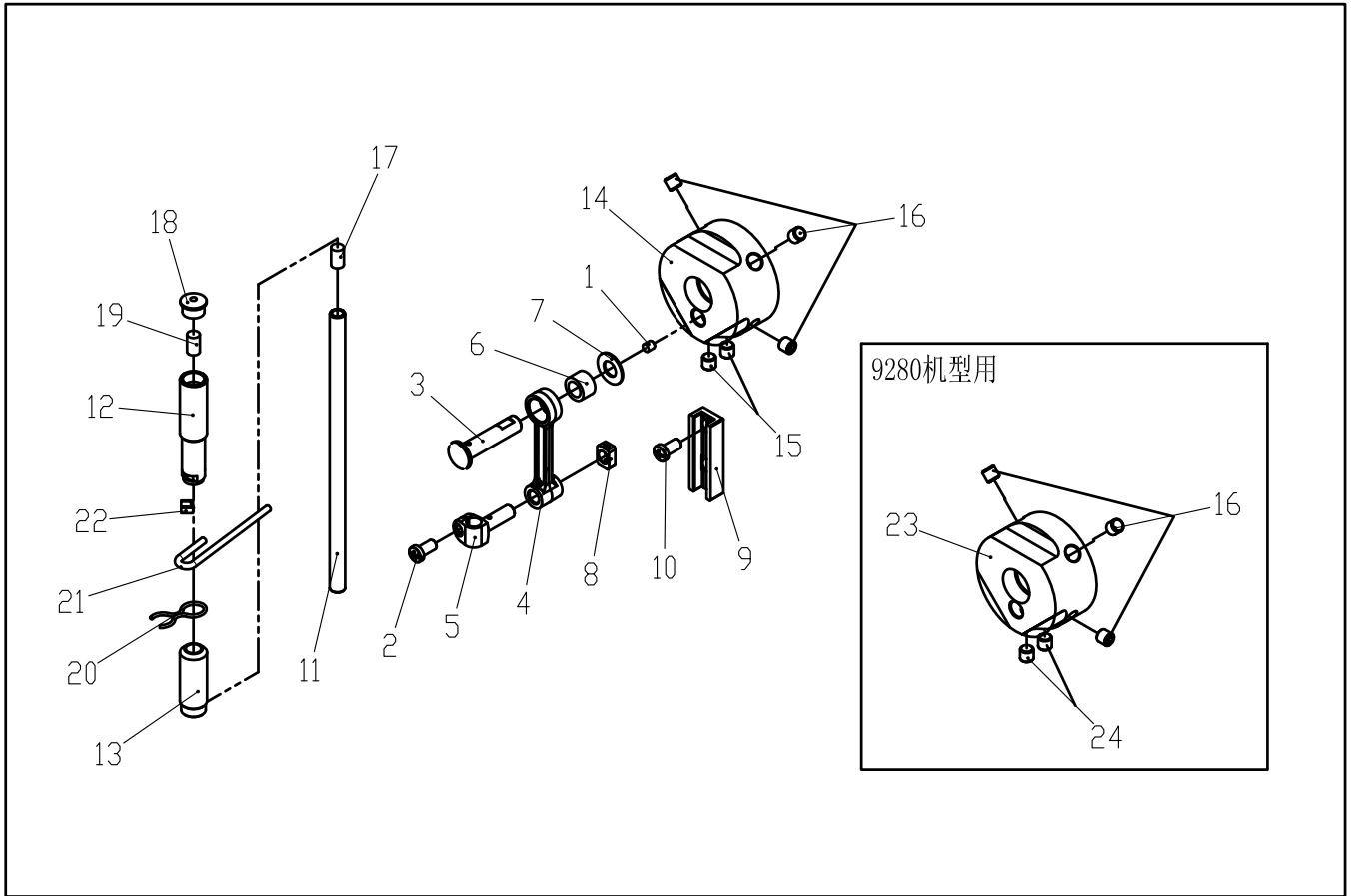

D1. 抬压脚部件 (9270) /Presser bar mechanism(9270)

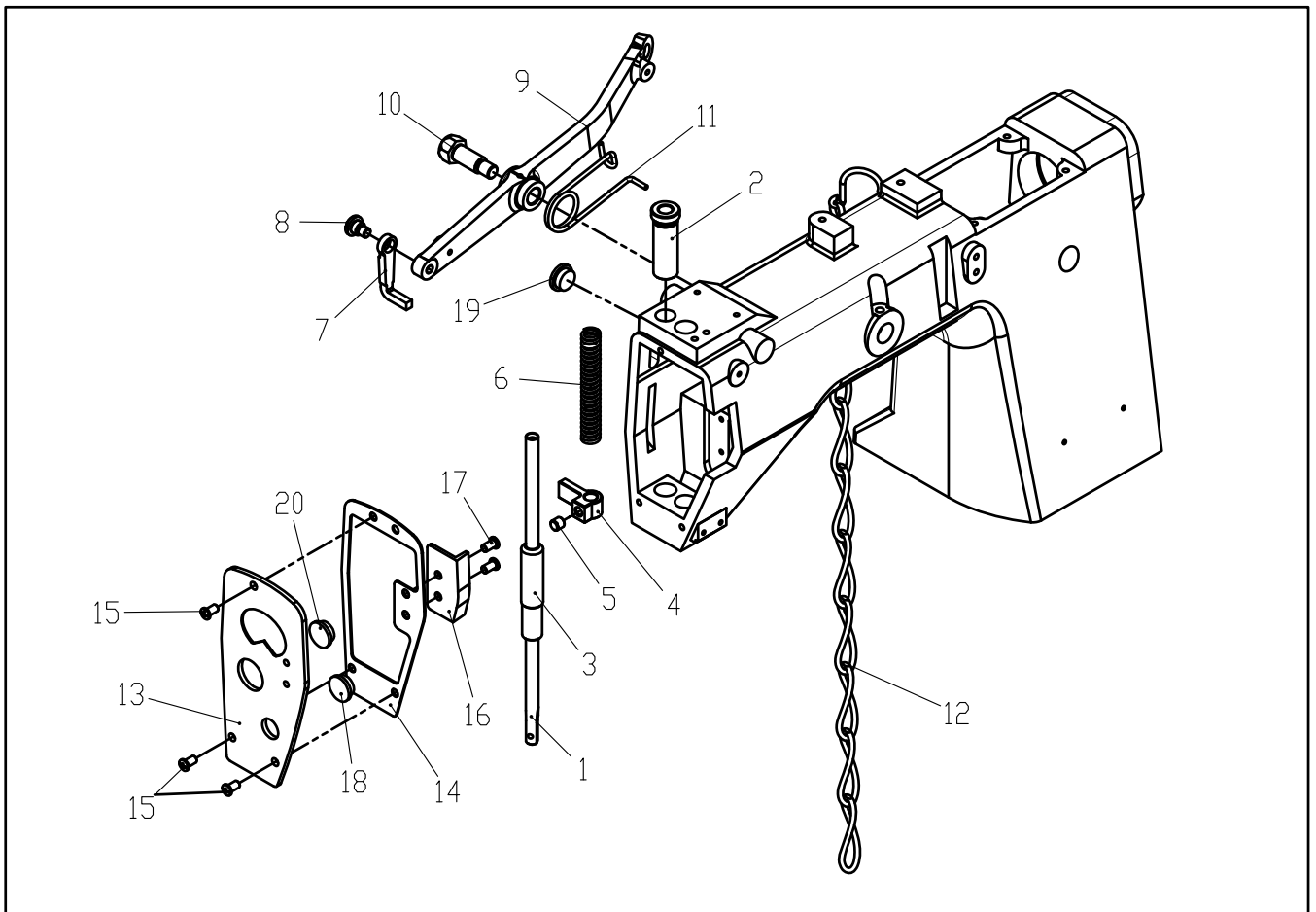

C. 针杆部件/Needle bar mechanism

序号 REF. NO.	件号 Part NO.	名称	Description	数量 Qty
1	40622005	防震橡胶垫	Rubber cap4.2	1
2	101S11005	螺钉	Screw ,SM3.57	1
3	40626001	挑线连杆销	Thread take-up lever pin	1
4	40605002	挑线连杆	Thread take-up lever	1
5	40626002	针杆连接轴	Needle bar connecting shaft	1
6	10124001	滚针轴承	Needle bearing	1
7	10112003	针杆曲柄护板	Washer	1
8	40609001	针杆滑块	Needle bar guide slide block	1
9	40601002	针杆滑块座	Needle bar guide	1
10	201S11009	螺钉	Screw pan SM3.57-40×6	2
11	40602009	针杆	Needle bar	1
12	40603002	针杆上套	Needle bar bush,U	1
13	40603003	针杆下套	Needle bar bush,D	1
14	40604001	针杆曲柄	Thread take-up crank,MH	1
15	116S14005	螺钉	Screw ,SM6.35	2
16	409s14001	螺钉	Screw SM6.35	3
17	40622006	橡皮塞	Needle bar cork	1
18	40622014	油封	Oil cup	1
19	10123002	油棉	Oil cotton	1
20	10112053	油线夹	Clutch felt wick nipper	1
21	12923018	回油线	Oil line	1
22	10127015	油线压紧簧	Ring	1
23	40604003	针杆曲柄	Thread take-up crank,H	1
24	409S14003	螺钉	Set screw, (CP)SM6.35	2

D1. 抬压脚部件 (9270) /Presser bar mechanism(9270)

序号 REF. NO.	件号 Part NO.	名称	Description	数量 Qty
1	40602002	压脚轴	Presser bar	1
2	406S30002	压脚螺母	Adjust screw	1
3	40603004	压脚轴套	Adjust screw bar	1
4	40609002	压杆导架	Adjust screw bar clamp	1
5	402S14006	压杆导架螺钉	SET SCREW, SOCKET, SM5.95	1
6	40627001	弹簧	Spring	1
7	40612004	抬压脚架	Presser bar lifter	1
8	406S20001	轴位螺钉	Shoulder screw ,SM5.95	1
9	300258	抬压脚杠杆	Knee lifter lever	1
10	406S20002	轴位螺钉	Shoulder screw ,SM7.94	1
11	40627002	杠杆弹簧	Twist spring	1
12	30131018	抬压脚拉链	Presser foot lifter chain assy	1
13	300259	面板	Pace plate	1
14	40622007	面板垫	Packing	1
15	406S11009	螺钉	Screw, pan SM4.37-40×10	4
16	40611002	挡板	Front lid	1
17	101S11007	螺钉	Screw, pan SM4.37-40×5	2
18	40122017	油封	Rubber cap, 13.5	1
19	40122005	油封	Rubber cap, 20.5	1
20	40122005	油封	Rubber cap, 20.5	1

D2. 抬压脚部件 (9280) /Presser bar mechanism (9280)

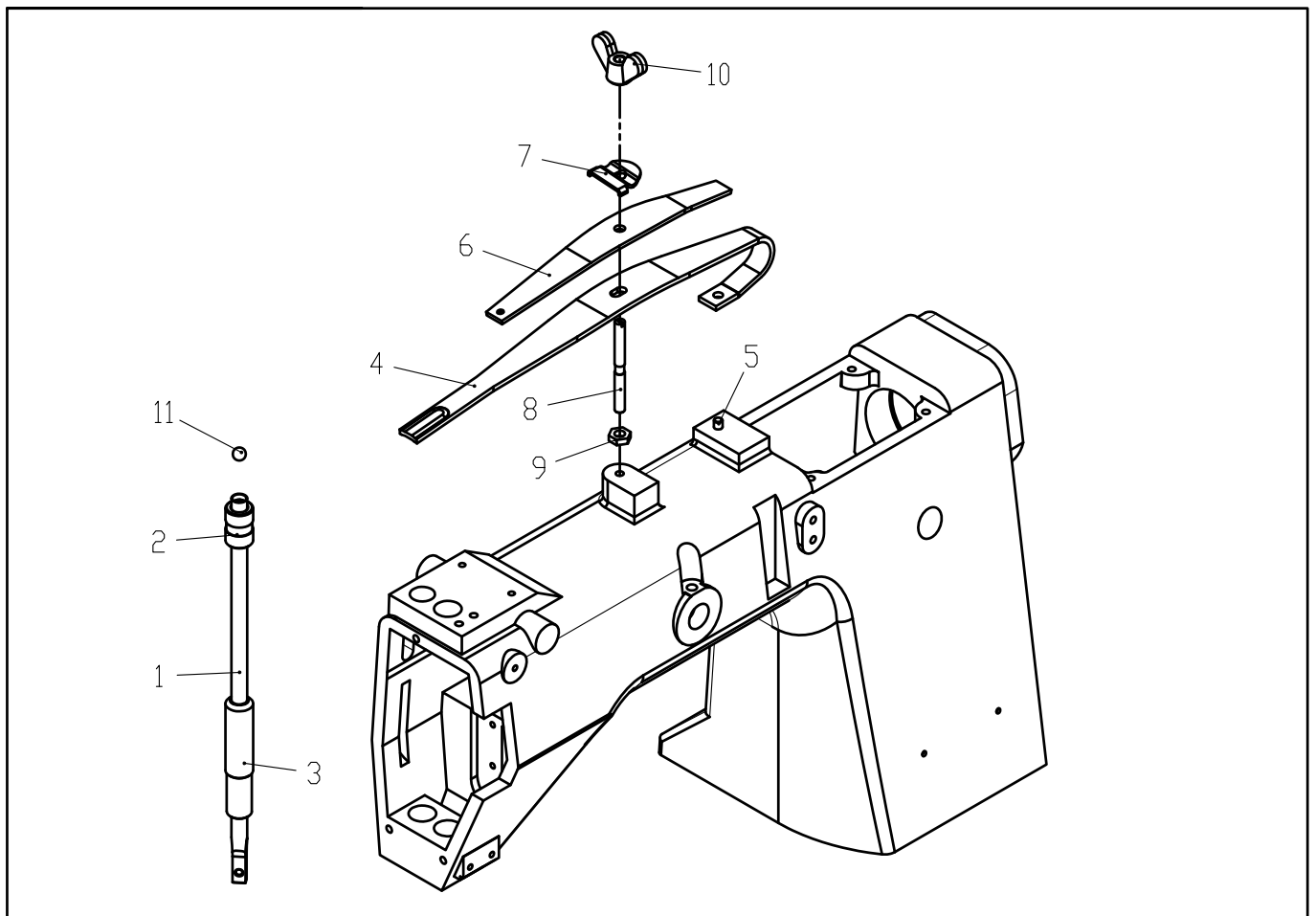

E. 带轮部件/Pulley mechanism

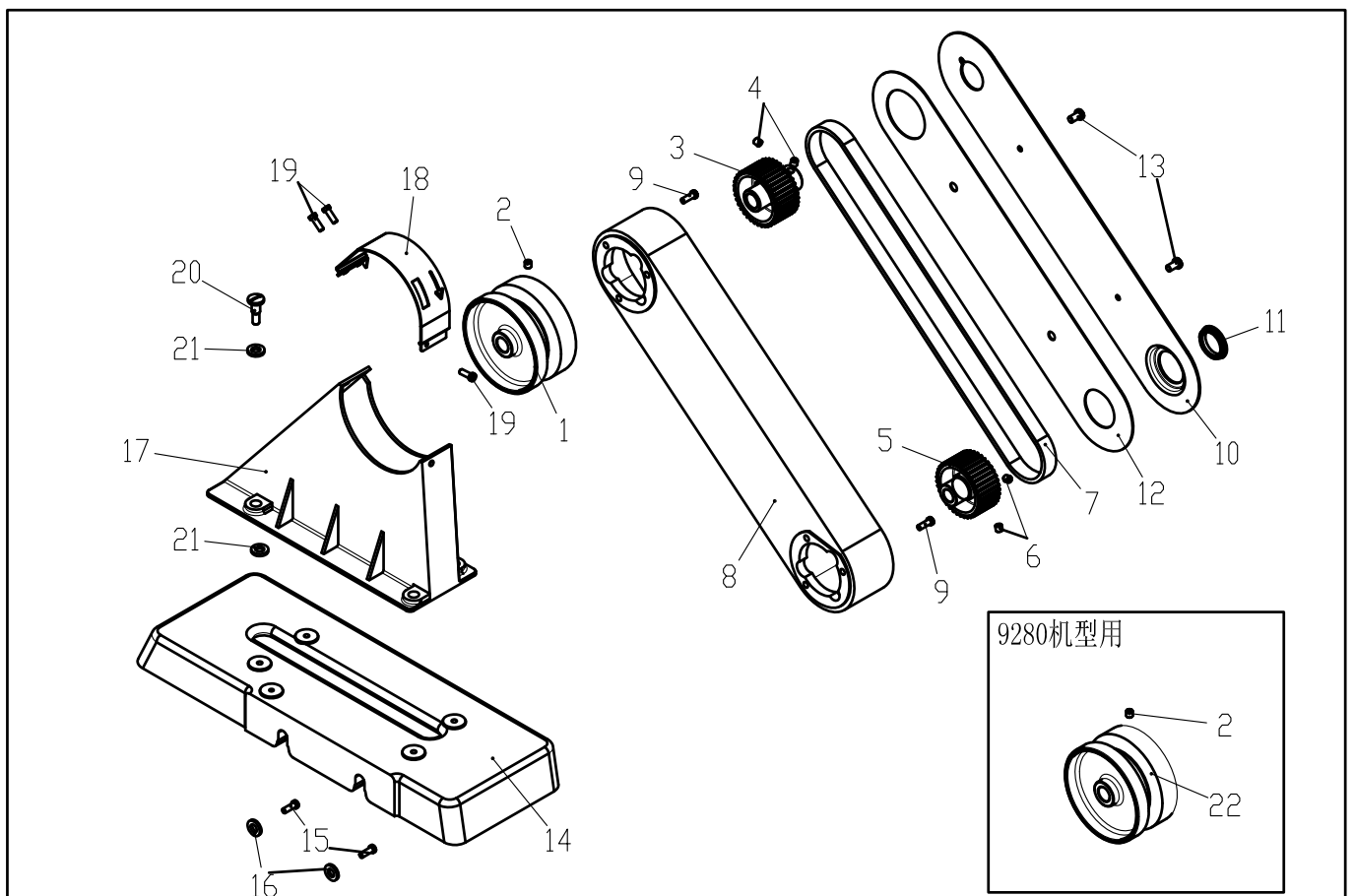

D2. 抬压脚部件 (9280) /Presser bar mechanism(9280)

序号 REF. NO.	件号 Part NO.	名称	Description	数量 Qty
1	40602003	压脚轴	Presser bar	1
2	40603005	压脚轴上套	Presser bar bush, U	1
3	40603006	压脚轴下套	Presser bar bush, D	1
4	40612006	弹簧片	Presser plate sping	1
5	40626003	销子	Pin	1
6	40612007	压板	Plate spring assy	1
7	40612008	垫片	Washer	1
8	406S30003	螺钉	Adjust screw	1
9	116S16006	螺母	Nut, 2 SM4. 76	1
10	406S16001	调压螺母	Presser bar lifter	1
11	40624006	钢珠	Rubber cap, 20. 5	1

E. 带轮部件/Pulley mechanism

序号 REF. NO.	件号 Part NO.	名称	Description	数量 Qty
1	300260	上轮	Pulley assy. M	1
2	101S15001	上轮螺钉	Set screw, socket SM6. 35	2
3	4063500400	上轴同步带轮	Timing belt wheel assy, upper	1
4	409S14001	上轴带轮螺钉	Set screw, socket SM6. 35	2
5	40635001	下轴同步带轮	Timing belt wheel assy, lower	1
6	116S14005	下轴带轮螺钉	Set screw, socket SM6. 35	2
7	40635002	传动带	Timing belt	1
8	300256	带轮箱	Belt cover	1
9	101S11016	螺钉	Screw pan SM4. 76-32×16	6
10	300261	带轮箱盖	Belt cover plate	1
11	40611003	下带轮罩	Rotary hook shaft cover	1
12	40622008	带轮箱垫	Packing	1
13	201S11020	螺钉	Screw pan SM4. 76-32×8	2
14	300257	底座	Pulley cover base	1
15	S01037	螺钉M12×30	Bolt	2
16	W01016	垫片12	Washer	2
17	40611004	上轮罩壳	Pulley cover , A	1
18	40612010	上轮顶盖	Pulley cover , B	1
19	105S11015	顶盖螺钉	Screw pan SM4. 37-40×7	3
20	406S20003	上轮罩壳螺钉	Stud screw, SM6. 35	4
21	40622009	垫片	Pulley cover sheet	8
22	300551	上轮	Pulley assy, H	1

F. 送料部件/Feed mechanism

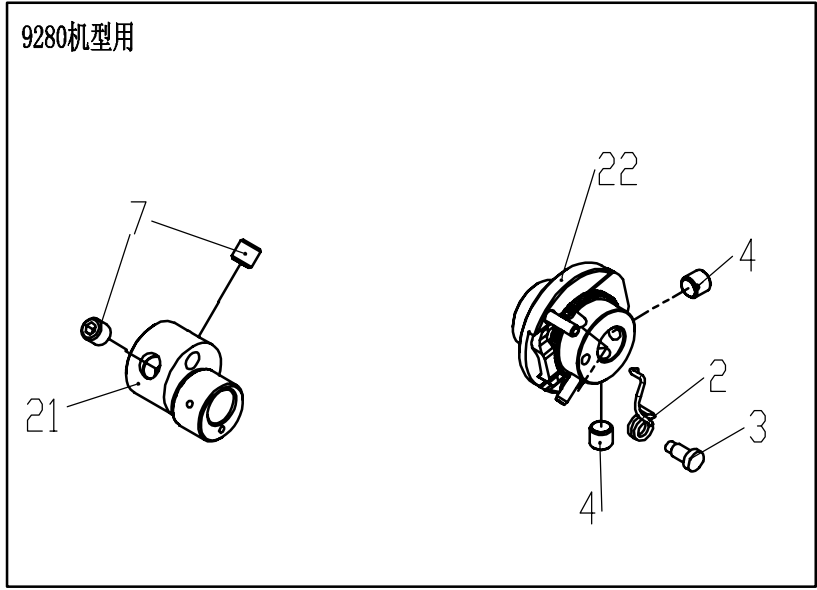
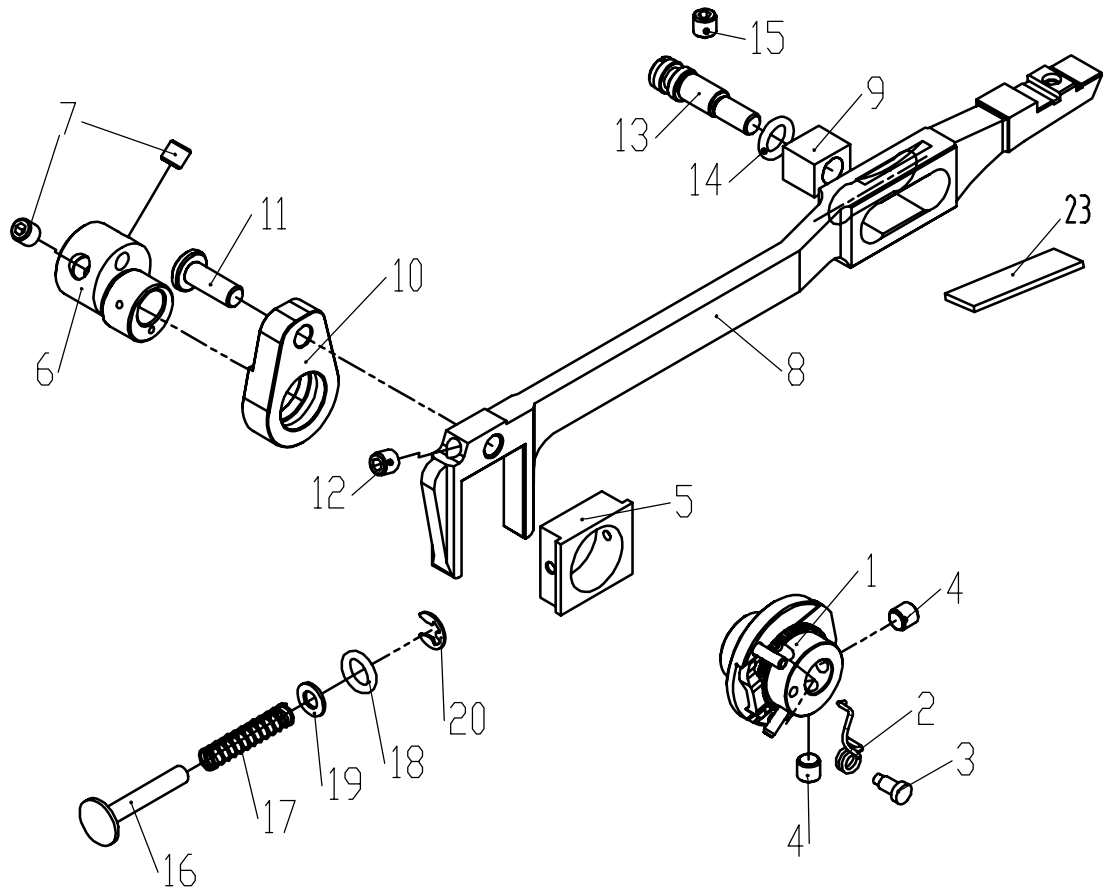

F. 送料部件/Feed mechanism

序号 REF. NO.	件号 Part NO.	名称	Description	数量 Qty
1	4061000100	送料凸轮组件	Eccentric wheel assy, M	1
2	40627003	弹簧	Twist spring	1
3	406S20009	螺钉	Screw, M3	1
4	403s14004	螺钉	Set screw, socket M6×6	2
5	40609003	送料滑块	Eccentric wheel sleeve	1
6	40610006	送料偏心轮	Eccentric wheel with screw, M	1
7	116S14004	螺钉	Set screw, socket SM6. 35	2
8	40606001	送料牙架	Feed bar slide block assy	1
9	40609004	牙架滑块	Feed bar slider	1
10	40604004	送料曲柄	Feed lifting connencting shaft	1
11	40626004	曲柄销	Feed lifting rock shaft	1
12	409S15002	螺钉	Set screw socket SM5. 95	1
13	40626005	送料偏心销	Feed bar eccentrics shaft	1
14	10122010	O型圈	O ring, P6	1
15	101S15010	螺钉	Set screw, socket SM5. 95	1
16	40626006	针距调节销	Push button	1
17	40627004	弹簧	Spring	1
18	10122010	O型圈	O ring, P5	1
19	20128025	垫片5	Washer, plain S4. 76	1
20	H05012	卡簧4	Retaining ring, E4	1
21	40610007	送料偏心轮	Eccentric wheel with screw, H	1
22	4061001100	送布凸轮组件	Eccentric wheel assy, H	1
23	40123008	油隔热板		1

G1. 两件关系/Gauge parts (9270 Standard)

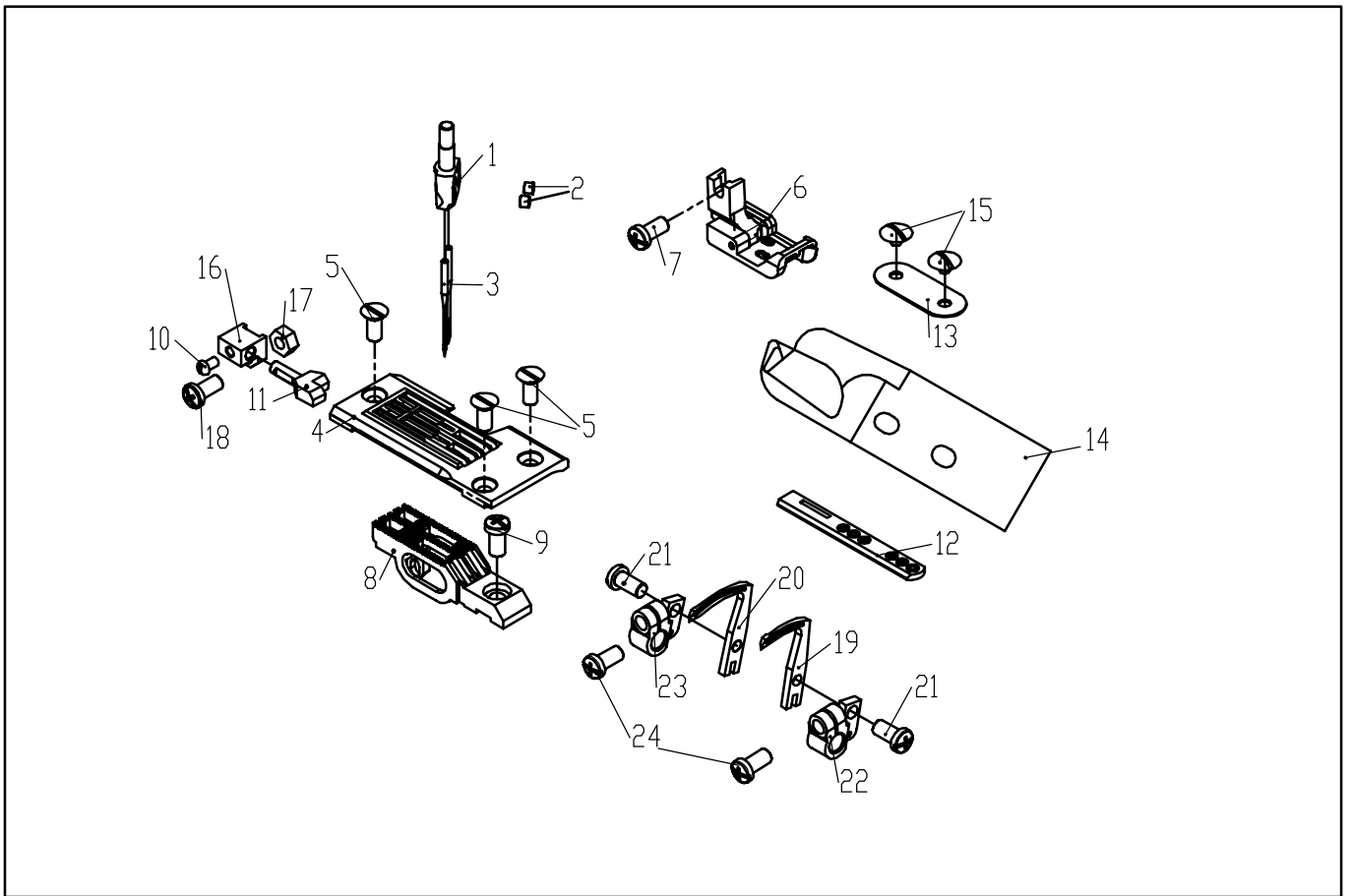

G2. 零件关系 (9280) Gauge parts (9280)

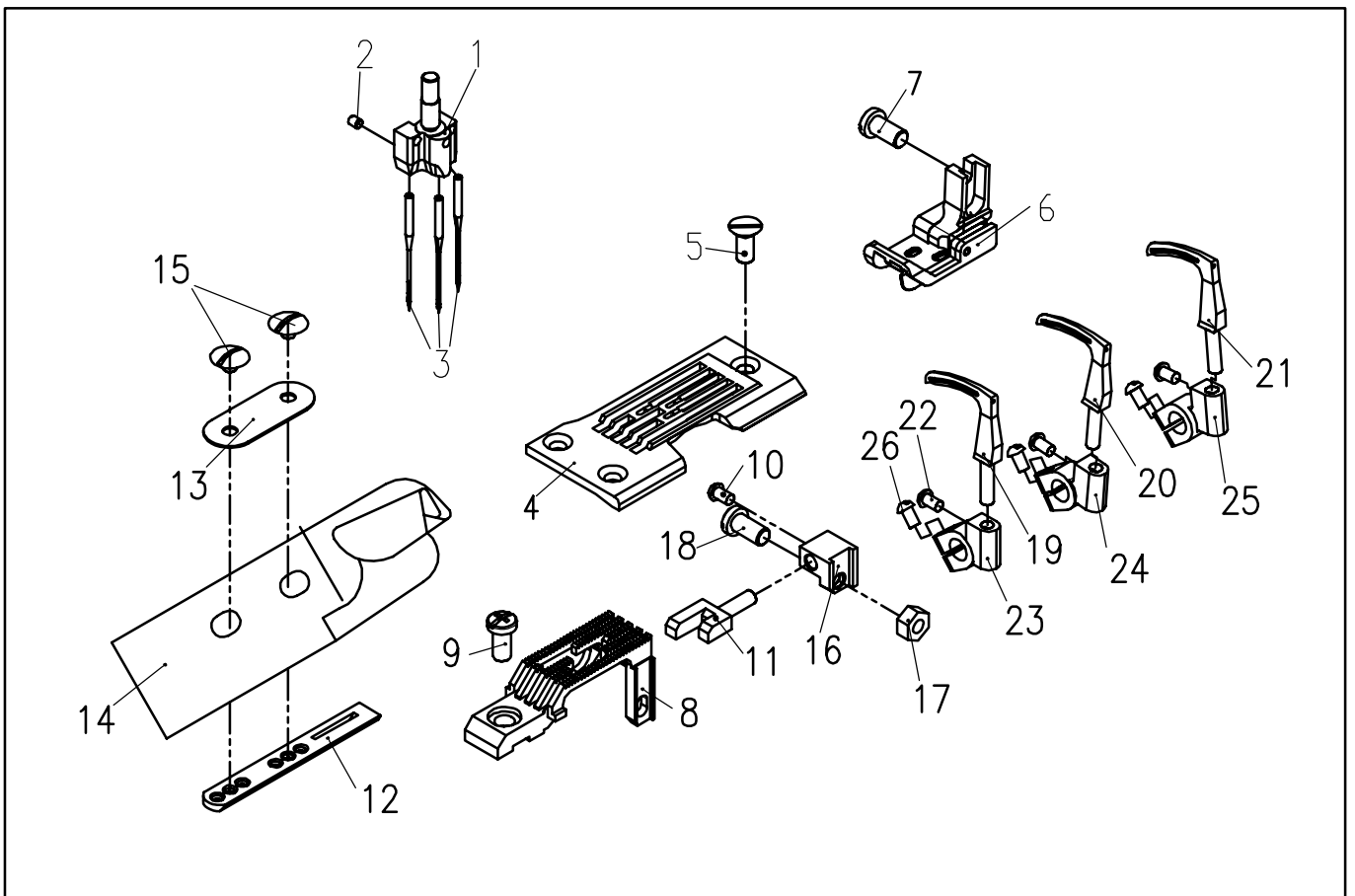

G1. 零件关系/Gauge parts (9270 Standard)

序号 REF. NO.	件号 Part NO.	名称	Description	数量 Qty
1	40634002	针夹头	Needle calmpassy w/s	1
2	125S15007	机针螺钉	Set csrew, SM4. 37	2
3	40617001	机针	Needle	2
4	40615002	针板	Needle plate	1
5	101S17002	针板螺钉	Screw flat SM4. 37	3
6	4061600200	压脚组件	Presser foot assy, 1/4"	1
7	101S11009	压脚螺钉	Screw bind SM3. 57-40×8	1
8	40614002	送料牙齿	Feed dog	1
9	402S11023	送料牙螺钉	Spring	1
10	-----	护针固定螺钉	Screw SM2. 38	1
11	40617008	护针	Needle guard	1
12	40609005	滑块	Lapper guide plate	1
13	40612011	安装板	Lapper guide plate washer	1
14	40615021	卷边器	Lapper assy	1
15	406S11002	安装板螺钉	Screw, SM3. 57	2
16	40604007	护针架	Needle guard bracket	1
17	-----	螺母	Needle guard	1
18	-----	螺钉	Lapper guide plate	1
19	40617011	前弯针	Lopper, S	1
20	40617017	后弯针	Looper, L	1
21	101S11007	弯针螺钉	Screw, SM3. 57	2
22	4060400500	前弯针架	Looper holder ,S	1
23	4060400600	后弯针架	Looper holder ,L	1
24	-----	螺钉	Lopper, S	2

G2. 零件关系/Gauge parts (9280 Standard)

序号 REF. NO.	件号 Part NO.	名称	Description	数量 Qty
1	40634007	针夹头	Needle calmpassy w/s	1
2	-----	机针螺钉	Set csrew, SM4. 37	2
3	40617005	机针	Needle	2
4	40615011	针板	Needle plate	1
5	101S17002	针板螺钉	Screw flat SM4. 37	3
6	40616010	压脚组件	Presser foot assy, 1/4"	1
7	101S11009	压脚螺钉	Screw bind SM3. 57-40×8	1
8	40614007	送料牙齿	Feed dog	1
9	402S11023	送料牙螺钉	Spring	1
10	-----	护针固定螺钉	Screw SM2. 38	1
11	40617021	护针	Needle guard	1
12	40609005	滑块	Lapper guide plate	1
13	40612011	安装板	Lapper guide plate washer	1
14	4061502700	卷边器	Lapper assy	1
15	406S11002	安装板螺钉	Screw, SM3. 57	2
16	40604007	护针架	Needle guard bracket	1
17	-----	螺母	Needle guard	1
18	-----	螺钉	Lapper guide plate	1
19	40617013	前弯针	Lopper, S	1
20	40617015	中弯针	Lopper, M	1
21	40617019	后弯针	Lopper, L	1
22	301S11023	弯针螺钉	Screw, SM3. 57	3
23	40604010	弯针架(前)	Looper holder ,S	1
24	40604008	弯针架(中)	Looper holder ,M	1
25	40604009	弯针架(后)	Looper holder ,L	1
26	413S13031	螺钉	Lopper, S	3

J. 下轴部件/Lower shaft mechanism

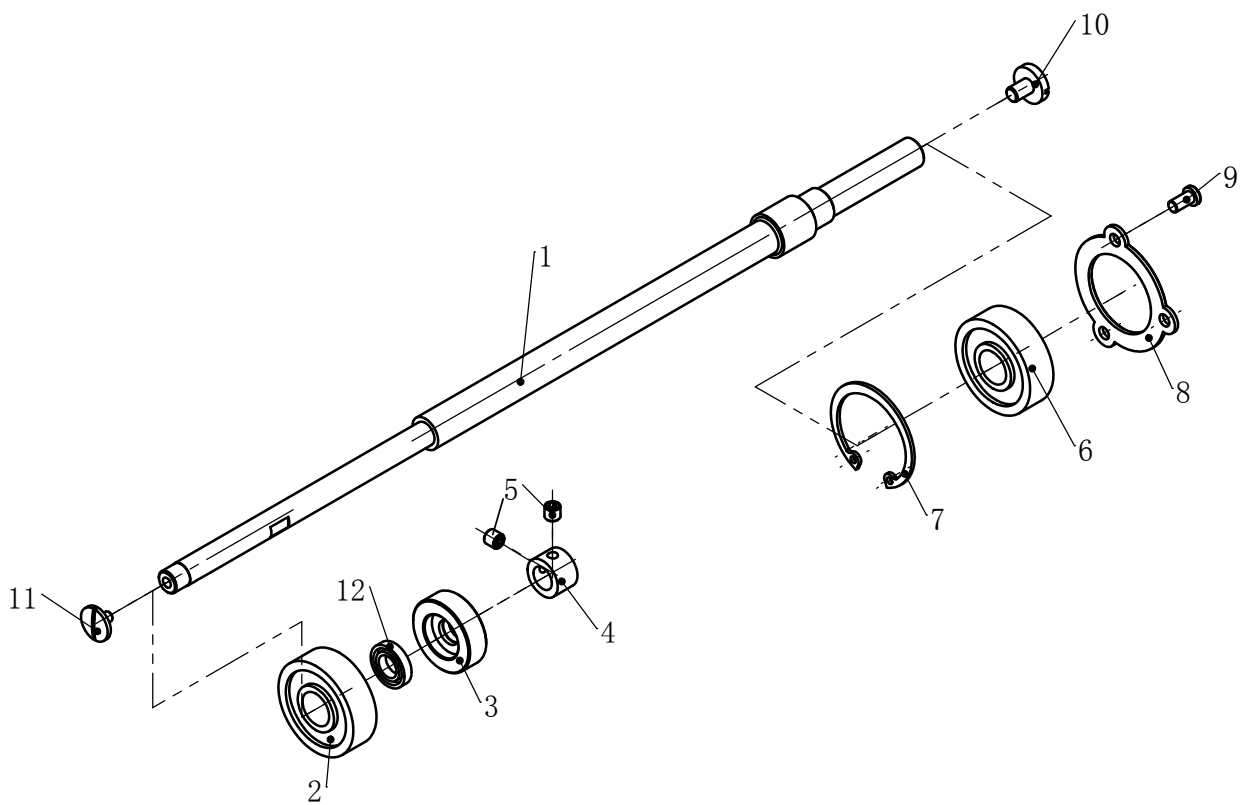

J. 下轴部件/Lower shaft mechanism

序号 REF. NO.	件号 Part NO.	名称	Description	数量 Qty
1	40602004	下轴	Lower shaft	1
2	B03003	轴承6200Z	Ball bearing, 6200Z	1
3	40608005	轴套	Shaft sleeve	1
4	40608002	下轴挡圈	Lower shaft collar	1
5	409s14002	挡圈螺钉	Set screw, SM4. 37	2
6	B01008	GB/T278轴承6302ZZ	Ball bearing, 6320VV	1
7	H01004	卡簧42	Retaining rig, C42	1
8	40612002	轴承盖	Bearing presser	1
9	402S11023	轴承盖螺钉	Screw , pan SM4. 76-32×10	3
10	406S11003	螺钉	Screw, SM6. 35	1
11	101S11023	螺钉	Screw, SM4. 37	1
12	20622019	油封	oil seal	1

K. 弯针轴部件/Looper mechanism

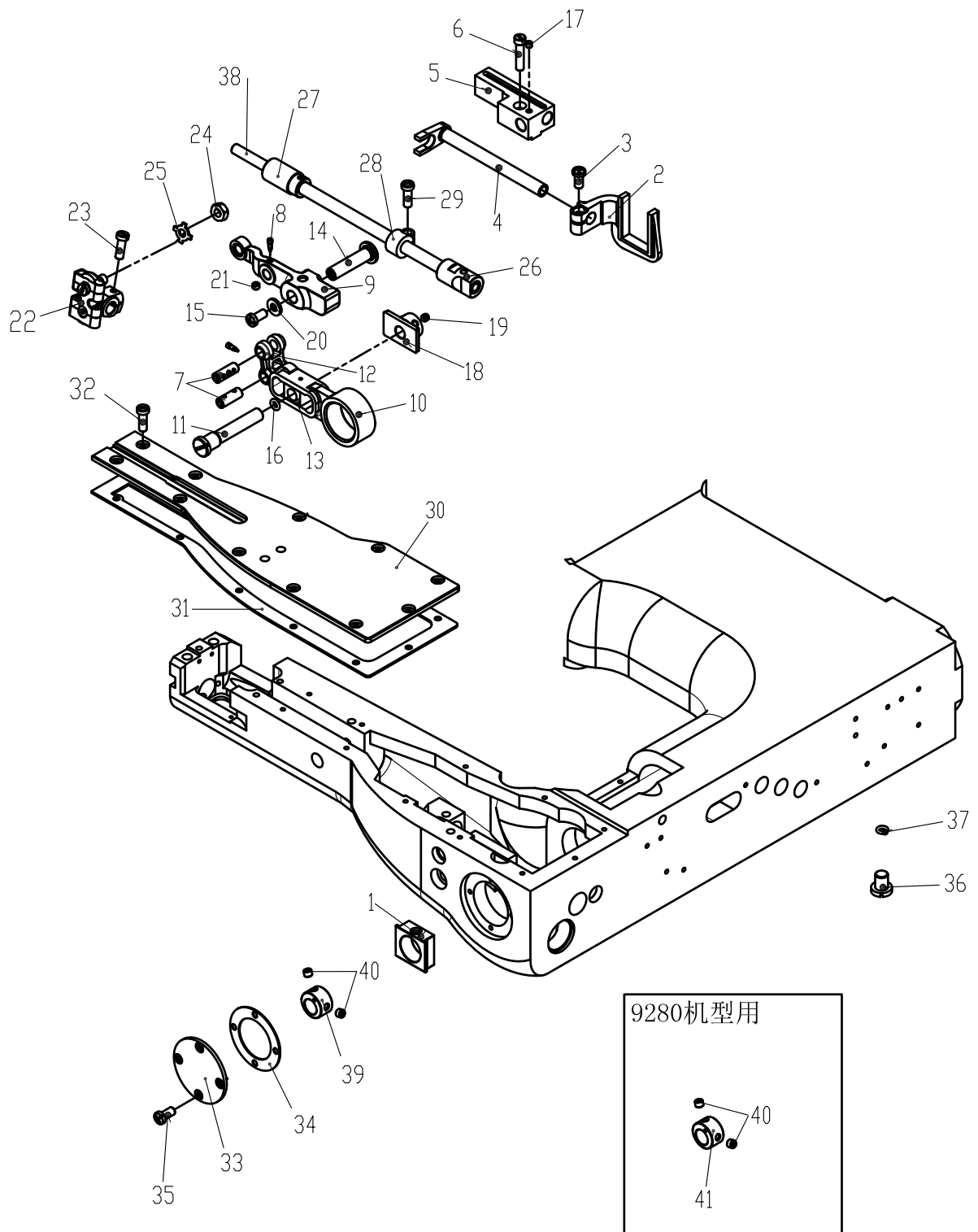

K. 弯针轴部件/Looper mechanism

序号 REF. NO.	件号 Part NO.	名称	Description	数量 Qty
1	400138	离合滑块	Slidee	1
2	40605003	弯针离合叉	Looper feeding fork assy	1
3	201S11020	螺钉	Screw, SM4. 37	1
4	40602005	弯针离合轴	Looper feeding fork shaft	1
5	401204	弯针离合轴座	Looper fork shaft bracket	1
6	406S30013	螺钉	Screw, SM4. 76	1
7	40626022	曲柄连接销	Looper link shaft	2
8	409S16020	螺钉	Screw, SM2. 38	2
9	40604012	离合曲柄	Looper lever	1
10	40604019	离合架	Looper holder	1
11	40626009	销子	Pin	1
12	40605004	曲柄	Lever	1
13	40609010	曲柄滑块	Lever slider	1
14	40626010	销子	Pin	1
15	406S11004	螺钉	Screw, SM4. 37	1
16	O01004	O型垫圈	O ring, S10	1
17	409S15004	螺钉	Set screw, SM5. 95	1
18	40608003	离合架销挡圈	Block plate	1
19	409S14002	螺钉	Screw	2
20	O01031	O形圈4×1.8	O ring	1
21	403S14004	螺钉	Screw SM5. 95	1
22	4060401500	弯针摆杆		1
23	201S11023	螺钉	Set screw	1
24	409S16020	螺母	Nut, SM5. 95	1
25	20128015	垫片	Washer	1
26	40603007	弯针轴后套	Looper shaft bush, F	1
27	40603008	弯针轴前套	Looper shaft bush, B	1
28	40608004	挡圈	Looper shaft set collar	1
29	201S11023	螺钉	Screw , pan SM4. 37-40×8	1
30	40612012	下仓盖	Front feed arm cap	1
31	40622010	下仓盖垫	Packing	1
32	101s11009	螺钉	Screw, SM3. 57	11
33	300263	下轴前盖	Ball bearing	1
34	40622011	垫片	Packing	1
35	401S11003	螺钉	Screw, pan SM3. 57-40×5	4
36	401S11029	螺钉	Screw, SM7. 94	1
37	O01031	O型圈	O ring , P7	1
38	40602006	弯针轴	Looper shaft	1
39	40610008	抬牙偏心轮	Eccentric wheel with screw	1
40	406S14002	螺钉	Screw	2
41	40610009	抬牙偏心轮	Eccentric wheel with screw	1

L1. 上线过线部件 (9270)/Upper threading mechanism (9270)

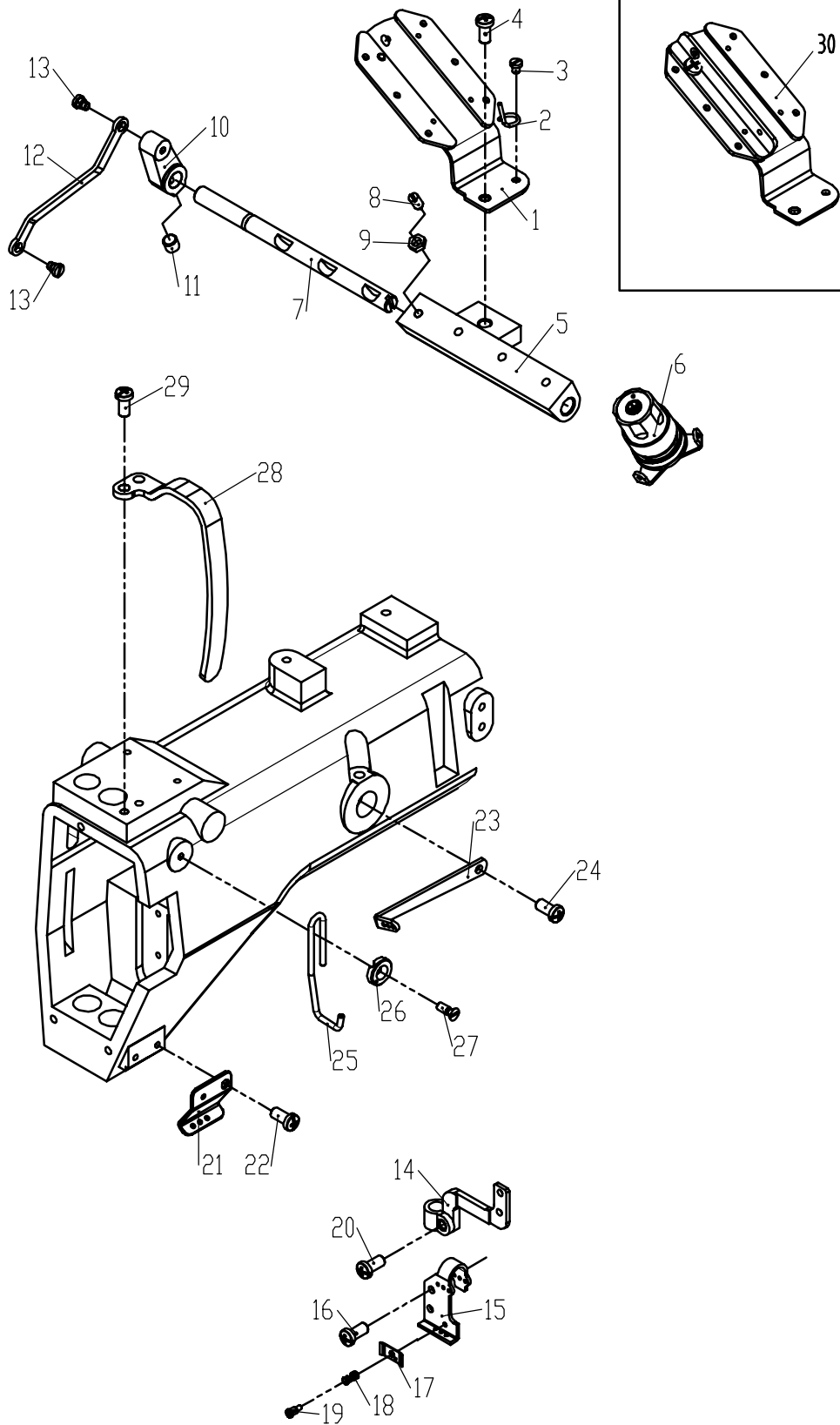

L1. 上线过线部件 (9270) Lower shaft mechanism

序号 REF. NO.	件号 Part NO.	名称	Description	数量 Qty
1	4061201400	面线导线支架板	Upper thread guide	1
2	40613001	过线勾	Thread guide	1
3	201S11010	螺钉	Screw, pan SM3. 57-40×5	1
4	116S11002	螺钉	Screw, pan SM4. 76-32×20	1
5	300264	面线松线器座	Upper thread tension bracket	1
6	4061303200	夹线器组件	yarn trapper	2
7	40602007	松线轴	Tension release shaft	1
8	406S30007	螺钉	Set screw, SM4. 37	1
9	201S16003	螺母	Nut, SM4. 37	1
10	40604016	松线曲柄	Tension release crank	1
11	201S14002	螺钉	Set screw, SM4. 37	1
12	40612015	连接板	Tension release connecting rod	1
13	406S20007	螺钉	Shoulder screw , SM3. 57	2
14	40605005	挑线杆部件	Upper thread take-up assy	1
15	40613002	挑线过线板	Upper thread guide	1
16	201S11005	螺钉	Screw, pan SM3. 18×5	2
17	40613003	过线压板	Upper thread take-up holder	1
18	20727002	弹簧	Spring	1
19	207S20003	轴位螺钉	Shoulder screw, SM2. 38	1
20	201S11008	螺钉	Screw, SM3. 57	1
21	40613004	过线板	Upper thread guide	1
22	201S11009	螺钉	Screw pan SM3. 57-40×7	1
23	40613005	张力缓线勾	Tension release lever	1
24	101S11010	螺钉	Screw bind SM3. 57-40×8	1
25	40613006	挑线过线架	Upper thread thake-up guide	1
26	400143	垫片	Washer	1
27	406S30005	螺钉	Screw flat SM3. 57	1
28	300268	防护罩	Thread thke-up cover	1
29	105S11015	螺钉	Screw pan SM4. 76-32×8	1
30	4061204400	三针用面线导线架支架板	Upper thread guide	1

L2. 上线过线部件 (9280) /Upper threading mechanism

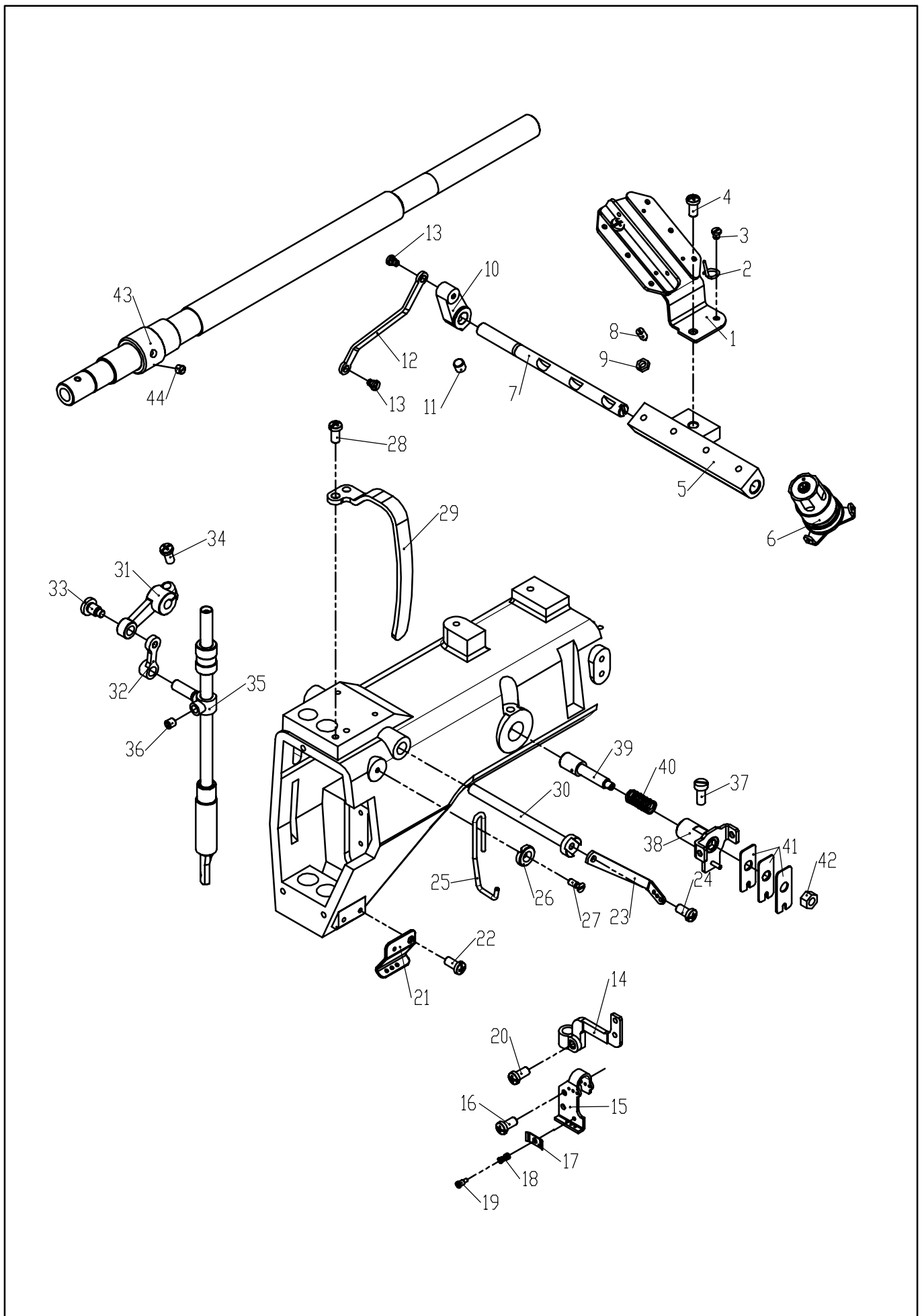

L2. 上线过线部件 (9280) /Upper threading mechanism(9280)

序号 REF. NO.	件号 Part NO.	名称	Description	数量 Qty
1	4061204400	三针用面线导线架支架板	Upper thread guide	1
2	40613001	过线勾	Thread guide	1
3	201S11010	螺钉	Screw, pan SM3. 57-40×5	1
4	116S11002	螺钉	Screw, pan SM4. 76-32×20	1
5	300264	面线松线器座	Upper thread tension bracket	1
6	4061303200	夹线器组件	yarn trapper	2
7	40602007	松线轴	Tension release shaft	1
8	406S30007	螺钉	Set screw, SM4. 37	1
9	201S16003	螺母	Nut, SM4. 37	1
10	40604016	松线曲柄	Tension release crank	1
11	201S14002	螺钉	Set screw, SM4. 37	1
12	40612015	连接板	Tension release connecting rod	1
13	406S20007	螺钉	Shoulder screw ,SM3. 57	2
14	40605005	挑线杆部件	Upper thread take-up assy	1
15	40613002	挑线过线板	Upper thread guide	1
16	201S11005	螺钉	Screw, pan SM3. 18×5	2
17	40613003	过线压板	Upper thread take-up holder	1
18	20727002	弹簧	Spring	1
19	207S20003	轴位螺钉	Shoulder screw, SM2. 38	1
20	201S11008	螺钉	Screw, SM3. 57	1
21	40613004	过线板	Upper thread guide	1
22	201S11009	螺钉	Screw pan SM3. 57-40×7	1
23	40613005	张力缓线勾	Tension release lever	1
24	101S11010	螺钉	Screw bind SM3. 57-40×8	1
25	40613006	挑线过线架	Upper thread thake-up guide	1
26	400143	垫片	Washer	1
27	406S30005	螺钉	Screw flat SM3. 57	1
28	105S11015	螺钉	Screw pan SM4. 76-32×8	1
29	300268	防护罩	Thread thke-up cover	1
30	40602008	打线传动轴		1
31	40604017	打线曲柄	T/release connecting rod assy	1
32	40605006	连杆	Tension release link	1
33	406S20008	螺钉	Shoulder screw, M4. 76	1
34	301S11007	螺钉	Screw SM3. 57	1
35	40626012	连接柱	Tension relwase stud	1
36	402S14006	螺钉	Set screw, SM5. 95	1
37	401S11009	螺钉	Set screw, SOCKET SM5. 95	1
38	40612020	压线板座	Upper therad tension bracket	1
39	40626013	松线轴	Upper thread stup assy	1
40	40627008	弹簧	Spring	1
41	40613011	压线板	Lower thread tension plate	1
42	—————	螺母	Nut	1
43	40610010	松线偏心套	—————	1
44	402S14006	螺钉	Set screw, SM5. 95	2

M1. 下线过线部件 (9270) / Lower threading mechanism(9270)

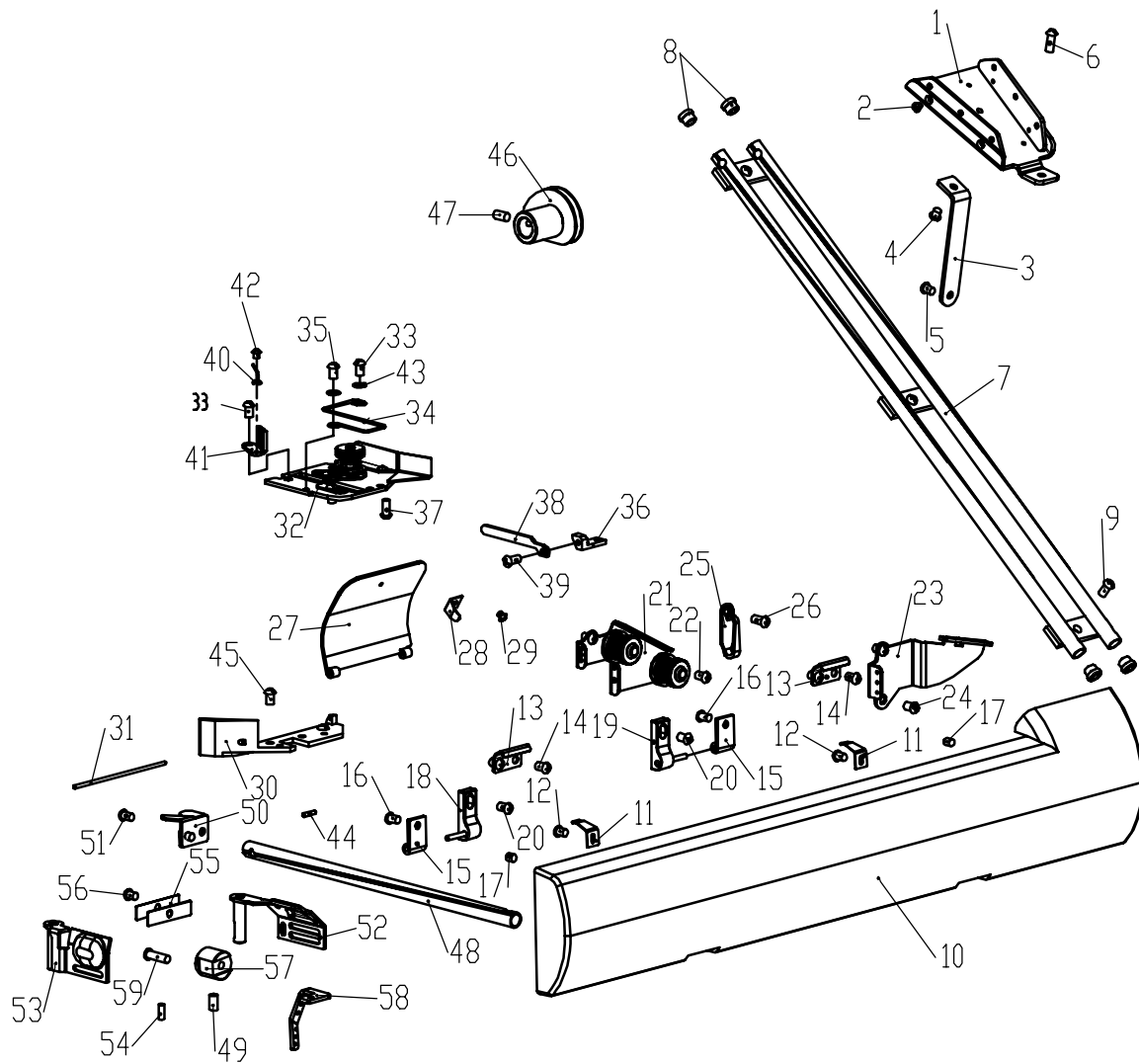

9270三针用

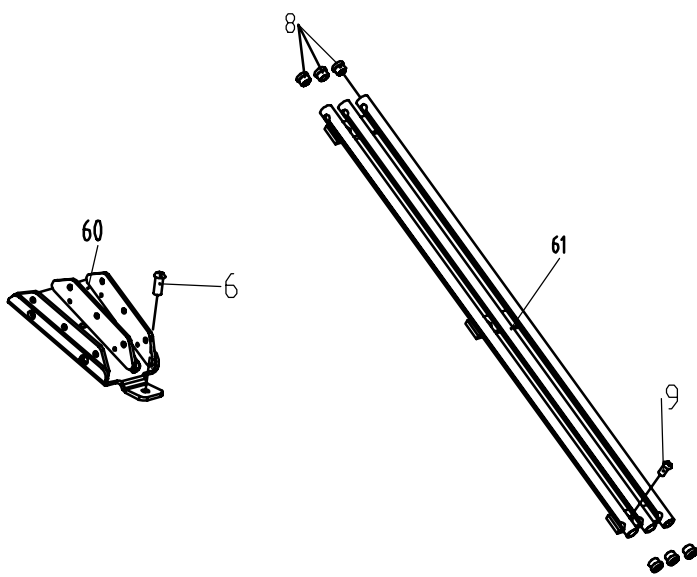

M1. 下线过线部件 (9270) /Lower threading mechanism (9270)

序号 REF. NO.	件号 Part NO.	名称	Description	数量 Qty
1	4061202100	底线导线安装板	Lower thread guide retainer	1
2	101S11019	螺钉	Screw flat SM2.38	4
3	40602021	支撑板	Lower thread guide support	1
4	402S11002	螺钉	Screw pan SM3.57-40×4	1
5	206S11002	螺钉	Screw pan SM3.57-40×5	1
6	206S11002	螺钉	Screw pan SM3.57-40×10	1
7	300265	过线管 (喷漆)	Inglinde guide tube assy	1
8	40613029	过线管塞	Crossed the line pipe plug	1
9	201S11009	螺钉	Screw pan SM3.57-40×8	3
10	300266	底线外盖	Front cover	1
11	40627012	底线外盖卡簧	Front cover spring	2
12	201S11009	螺钉	Screw pan SM3.57-40×5	2
13	40612022	盖板固定板	Front cover hook	2
14	201S11009	螺钉	Screw pan SM3.57-40×6	4
15	40612023	转动架	Hing	2
16	201S11009	螺钉	Screw pan SM3.57-40×6	2
17	40622005	缓冲垫	Rubber cap 4.2	2
18	40601009	左转动架	Thread guide hing assy,L	1
19	40601010	右转动架	Thread guide hing assy,R	1
20	201S11009	螺钉	Screw pan SM3.57-40×6	2
21	4061301200	夹线器安装板	Lower thread guide	1
22	201S11009	螺钉	Screw pan SM3.57-40×6	2
23	4061301300	过线板	Lower thread guide	1
24	201S11009	螺钉	Screw pan SM3.57-40×6	2
25	40613032	大线钩	Arm thread guide M	1
26	116S17002	螺钉	Screw flat SM3.57	1
27	300267	打线凸轮盖	Thread take-up lever cover	1
28	40627009	卡簧	Spring, plate	1
29	101S11019	螺钉	Screw, SM2.38	1
30	40601011	底线转向过线板	Take-up lever bracket	1
31	40626015	打线凸轮盖销	Take-up lever cov. Shaft	1
32	4061202500	凸轮导线架	Take-up lever bracket	1
33	101S11005	螺钉	Screw pan SM3.57-40×6	2
34	40627010	导线钢丝	Lower thread guide	1
35	201S11033	螺钉	Screw bind SM3.18-40×4	1

M1. 下线过线部件 (9270) / Lower threading mechanism(9270)

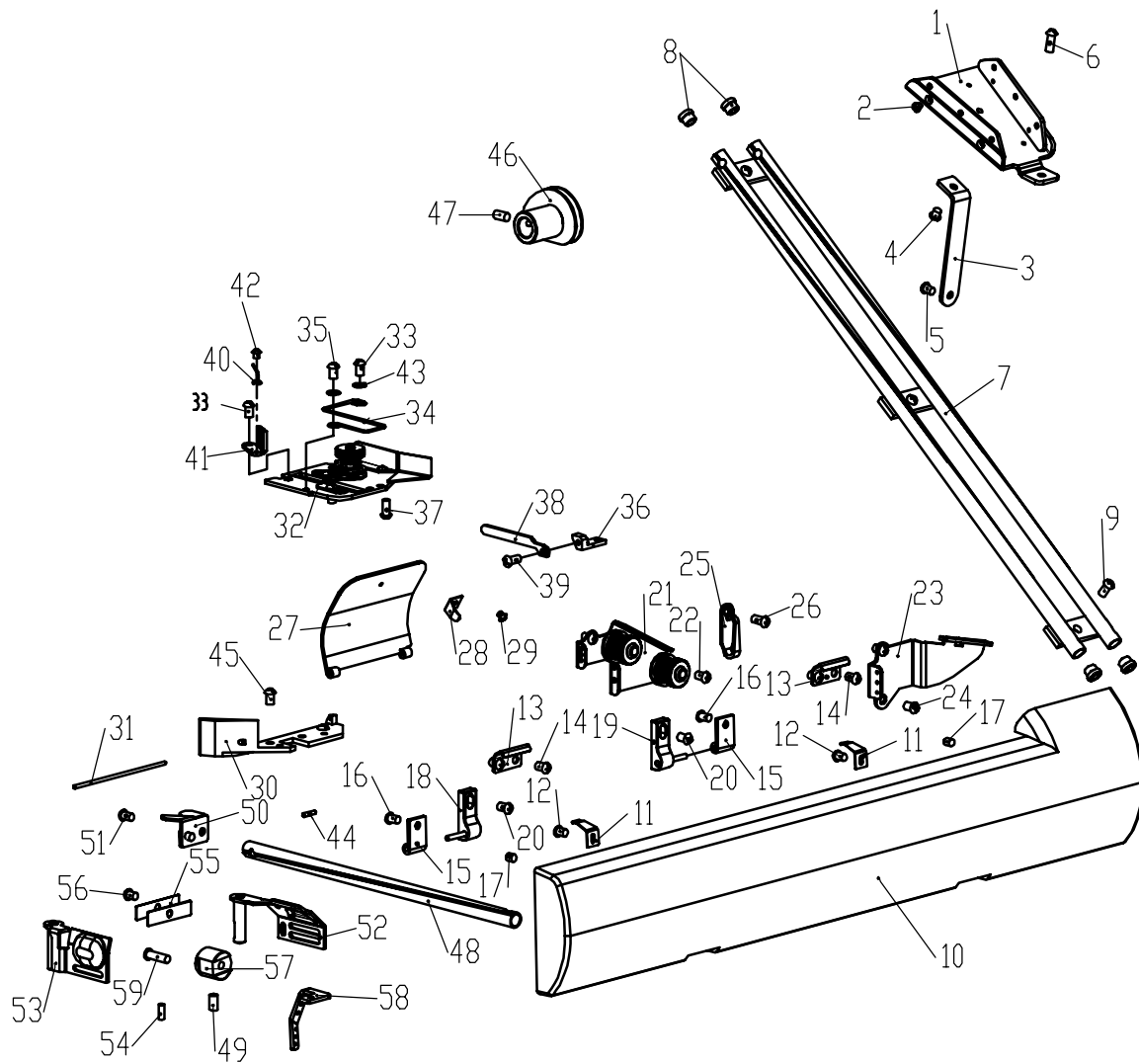

9270三针用

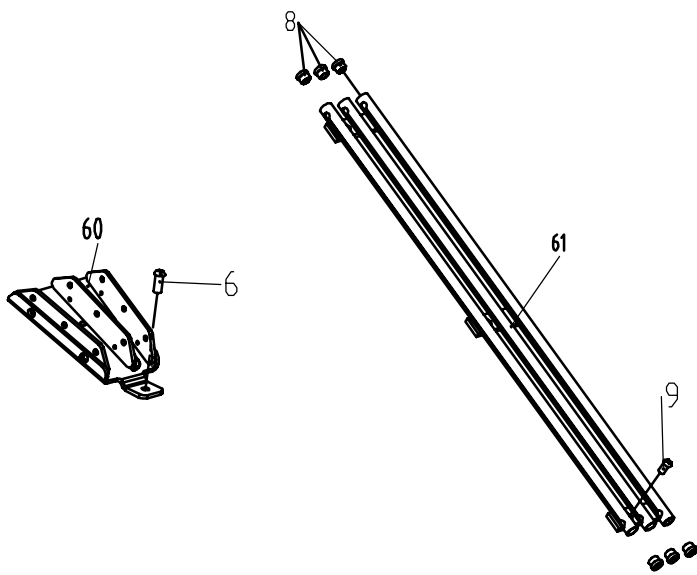

36	40609007	底线打线架	Thread release base	1
37	201S11005	螺钉	Scerw pan SM3.18-40×4	2
38	40612027	底线打线板	Lower thread presser	1
39	201S11005	螺钉	Scerw pan SM3.18-40×4	1
40	40613017	压线钢丝	Thread guide	1
41	40613018	导线架	Lower thread guide plate	1
42	209S11007	螺钉	Screw SM2.38	1
43	40928021	垫圈3	Washer ,plain S3	2
44	P03014	销5×12.5	Pin spring roll AW5	1
45	301S11007	螺钉	Screw SM3.57	2
46	4061301900	打线凸轮	Lower thread take-up W/S,M	1
47	409S14002	螺钉	SET screw, SOCKET (CP) SM4.37	2
48	40613020	底线过线管	Lower thread feed bar guide	1
49	409S15004	螺钉	Set screw, SM5.95	1
50	40619005	切线刀	Thread trimmer guide plate	1
51	403S11017	螺钉	Screw ,pan SM3.57-40×6	1
52	40612028	右弯针盖	Looper cover, RA	1
53	40612029	左弯针盖	Looper cover, LA	1
54	P03015	销2×8.5	Pin, spring roll AW2	1
55	40612030	弯针盖压板	Spring	2
56	201S11009	螺钉	Screw ,pan SM3.57-40×7	1
57	40601012	护针支架	Looper thread guide bracket	1
58	40613024	导线架	Looper thread guide	1
59	201S11037	螺钉	Screw pan SM3.57-40×14	1
60	4061204500	底线导线安装板	Lower thread guider retaner	1
61	300552	过线管（喷漆）	Inglinde guide tube assy	1

M2. 下线过线部件 (9280) /Lower threading mechanism(9280)

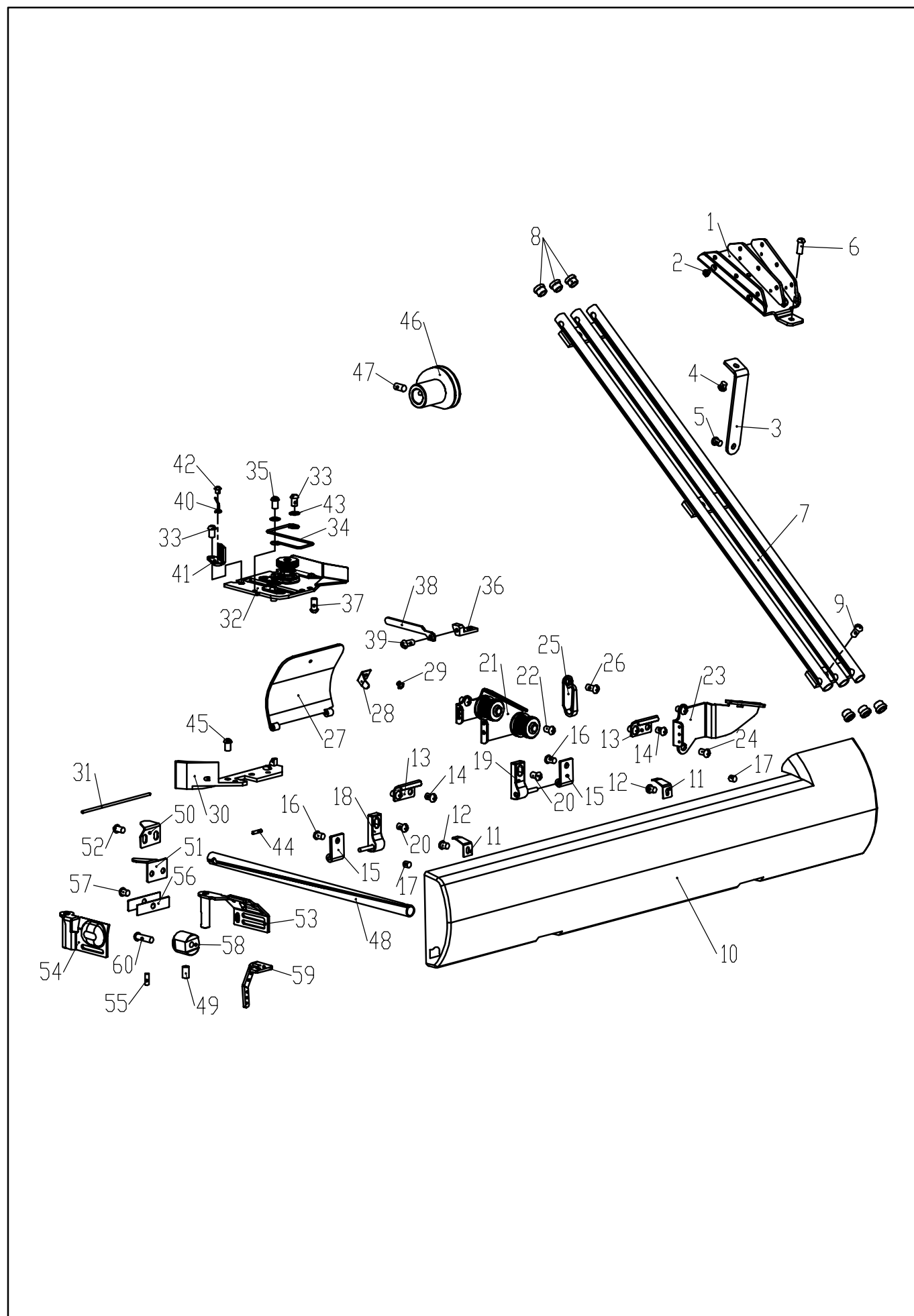

M2. 下线过线部件 (9280) /Lower threading mechanism (9280)

序号 REF. NO.	件号 Part NO.	名称	Description	数量 Qty
1	4061204500	底线导线安装板	Lower thread guide retainer	1
2	101S11019	螺钉	Screw flat SM2.38	4
3	40602021	支撑板	Lower thread guide support	1
4	402S11002	螺钉	Screw pan SM3.57-40×4	1
5	206S11002	螺钉	Screw pan SM3.57-40×5	1
6	206S11002	螺钉	Screw pan SM3.57-40×10	1
7	300552	过线管 (喷漆)	Inglinde guide tube assy	1
8	40613029	过线管塞	Crossed the line pipe plug	1
9	201S11009	螺钉	Screw pan SM3.57-40×8	3
10	300266	底线外盖	Front cover	1
11	40627012	底线外盖卡簧	Front cover spring	2
12	201S11009	螺钉	Screw pan SM3.57-40×5	2
13	40612022	盖板固定板	Front conver hook	2
14	201S11009	螺钉	Screw pan SM3.57-40×6	4
15	40612023	转动架	Hing	2
16	201S11009	螺钉	Screw pan SM3.57-40×6	2
17	40622005	缓冲垫	Rubber cap 4.2	2
18	40601009	左转动架	Thread guide hing assy,L	1
19	40601010	右转动架	Thread guide hing assy,R	1
20	201S11009	螺钉	Screw pan SM3.57-40×6	2
21	4061301200	夹线器安装板	Lower thread guide	1
22	201S11009	螺钉	Screw pan SM3.57-40×6	2
23	4061301300	过线板	Lower thread guide	1
24	201S11009	螺钉	Screw pan SM3.57-40×6	2
25	40613032	大线钩	Arm thread guide M	1
26	116S17002	螺钉	Screw flat SM3.57	1
27	300267	打线凸轮盖	Thread take-up lever cover	1
28	40627009	卡簧	Spring, plate	1
29	101S11019	螺钉	Screw, SM2.38	1
30	40601011	底线转向过线板	Take-up lever bracket	1
31	40626015	打线凸轮盖销	Take-up lever cov. Shaft	1
32	4061202500	凸轮导线架	Take-up lever bracket	1
33	101S11005	螺钉	Screw pan SM3.57-40×6	2
34	40627010	导线钢丝	Lower thread guide	1
35	201S11033	螺钉	Screw bind SM3.18-40×4	1

M2. 下线过线部件 (9280) /Lower threading mechanism(9280)

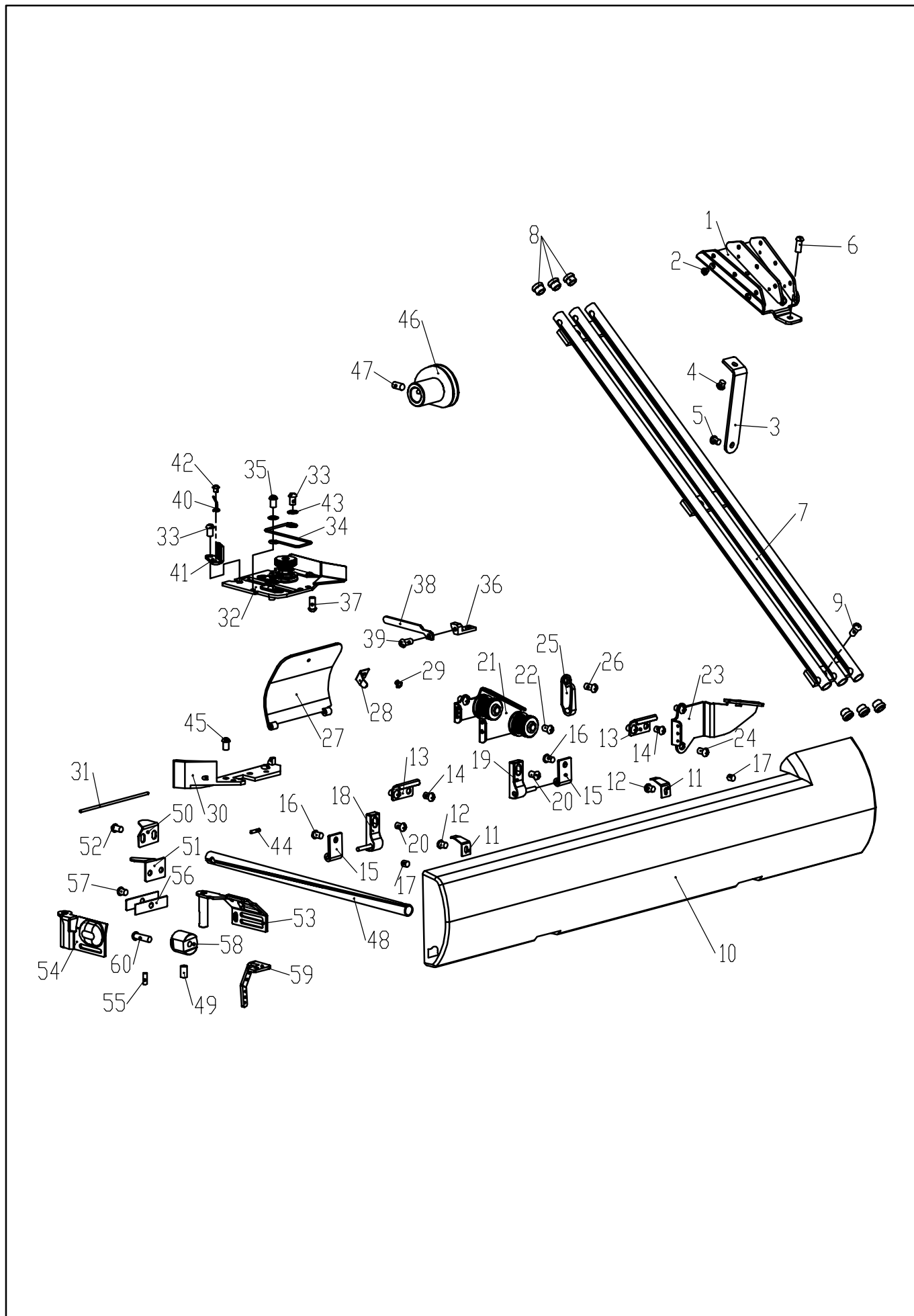

36	40609007	底线打线架	Thread release base	1
37	201S11005	螺钉	Scerw pan SM3.18-40×4	2
38	40612027	底线打线板	Lower thread presser	1
39	201S11005	螺钉	Scerw pan SM3.18-40×4	1
40	40613017	压线钢丝	Thread guide	1
41	40613018	导线架	Lower thread guide plate	1
42	209S11007	螺钉	Screw SM2.38	1
43	40928021	垫圈3	Washer ,plain S3	2
44	P03014	销5×12.5	Pin spring roll AW5	1
45	301S11007	螺钉	Screw SM3.57	2
46	40613026	打线凸轮	Lower thread take-up W/S,M	1
47	409S14002	螺钉	SET screw, SOCKET (CP) SM4.37	2
48	40613020	底线过线管	Lower thread feed bar guide	1
49	409S15004	螺钉	Set screw, SM5.95	1
50	40619003	上切线刀	Thread trimmer guide plate	1
51	40619005	下切线刀	Thread trimmer	1
52	403S11017	螺钉	Screw ,pan SM3.57-40×6	1
53	40612031	右弯针盖	Looper cover, RA	1
54	40612032	左弯针盖	Looper cover, LA	1
55	P03015	销2×8.5	Pin, spring roll AW2	1
56	40612030	弯针盖压板	Spring	2
57	201S11009	螺钉	Screw ,pan SM3.57-40×7	1
58	40601012	护针支架	Looper thread guide bracket	1
59	40613024	导线架	Looper thread guide	1
60	201S11037	螺钉	Screw pan SM3.57-40×14	1

2PL/PL专用部件/ Special components for 2PL/PL

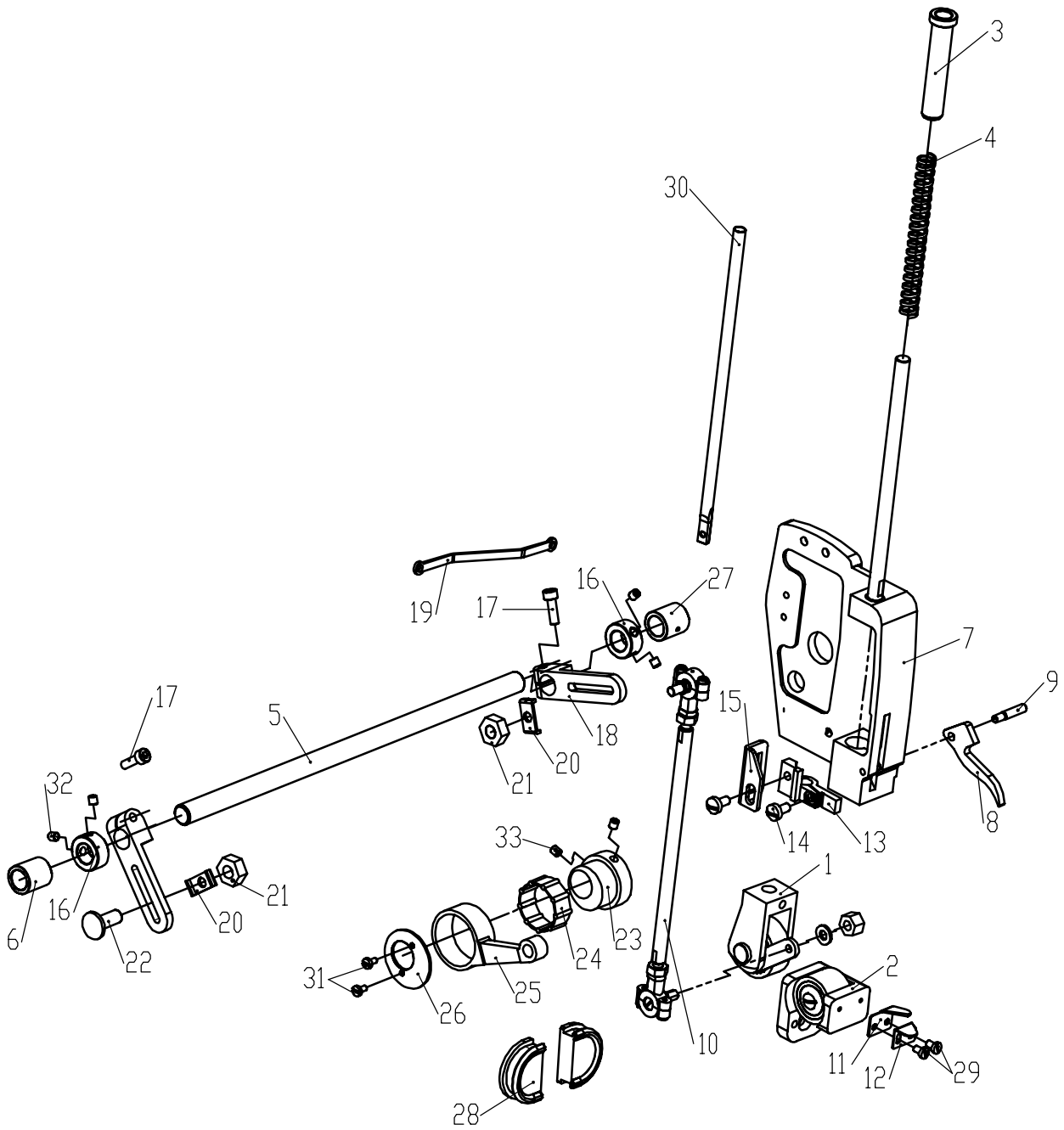

9280PL机型用

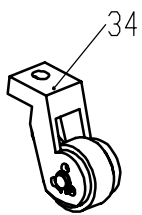

92802PL机型用

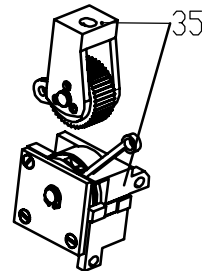

2PL/PL专用部件/Special components for 2PL/PL

序号 REF. NO.	件号 Part NO.	名称	Description	数量 Qty
1	4061402700	上拖轮组件	Upper plastic wheel ass.	1
2	4061402500	下拖轮组件	Lower plastic wheel ass.	1
3	40603019	调节螺母	Adjusting screw	1
4	40627014	压脚弹簧	Presser spring	1
5	40602017	长轴	Long shaft	1
6	40603016	长轴铜套(后)	Long shaft tube(back)	1
7	301151	边盖	Top cover	1
8	40601031	抬压扳手	Lift pressure wrench	1
9	40602013	固定销子	Wrench pin	1
10	4060402400	拉杆组件	Joint bearing base	1
11	40619003	上切线刀	Thread trimmer guide plate	1
12	40619005	下切线刀	Thread trimmer	1
13	40609009	压杆连接块	Voltage regulating rod clamp	1
14	S05038	压杆连接块螺钉	Voltage regulating rod clamp s	1
15	40612047	连接板	Connecting Piece	1
16	40603020	挡圈	Block ring	2
17	S05004	调节连杆螺钉	Adjusttting rod screw	2
18	40605010	调节连杆	Adjusttting rod	2
19	40612045	松线连杆	Thread tension connectting rod	1
20	40612048	刻度指示片	Dial indicating piece	2
21	401S16002	螺母	Screw	2
22	406S20010	调节杆轴位螺钉	Adjusting rod screw	1
23	40610012	偏心轮	Eccentric wheel	1
24	B07036	滚针轴承	Needle bearing	1
25	40605009	连杆	Connecting rod	1
26	40612050	偏心轮挡片	Eccentric wheel piece	1
27	40603013	长轴铜套	Long shaft tube	1
28	40622016	橡胶塞	Rubber plug	2
29	403S11017	刀片固定螺钉	Blade set screw	2
30	40602016	压脚杆	Presser foot rod	1
31	409s11013	挡片固定螺钉	Block piece set screw	2
32	S09002	挡圈固定螺钉	Block ring set screw	4
33	116S14005	螺钉	Screw , SM6.35	2
34	4061400800	拖轮组件	Upper plastic wheel ass.	1
35	4061401900	拖轮组件	Upper puller ass.	1

PS专用件/Special components for PS

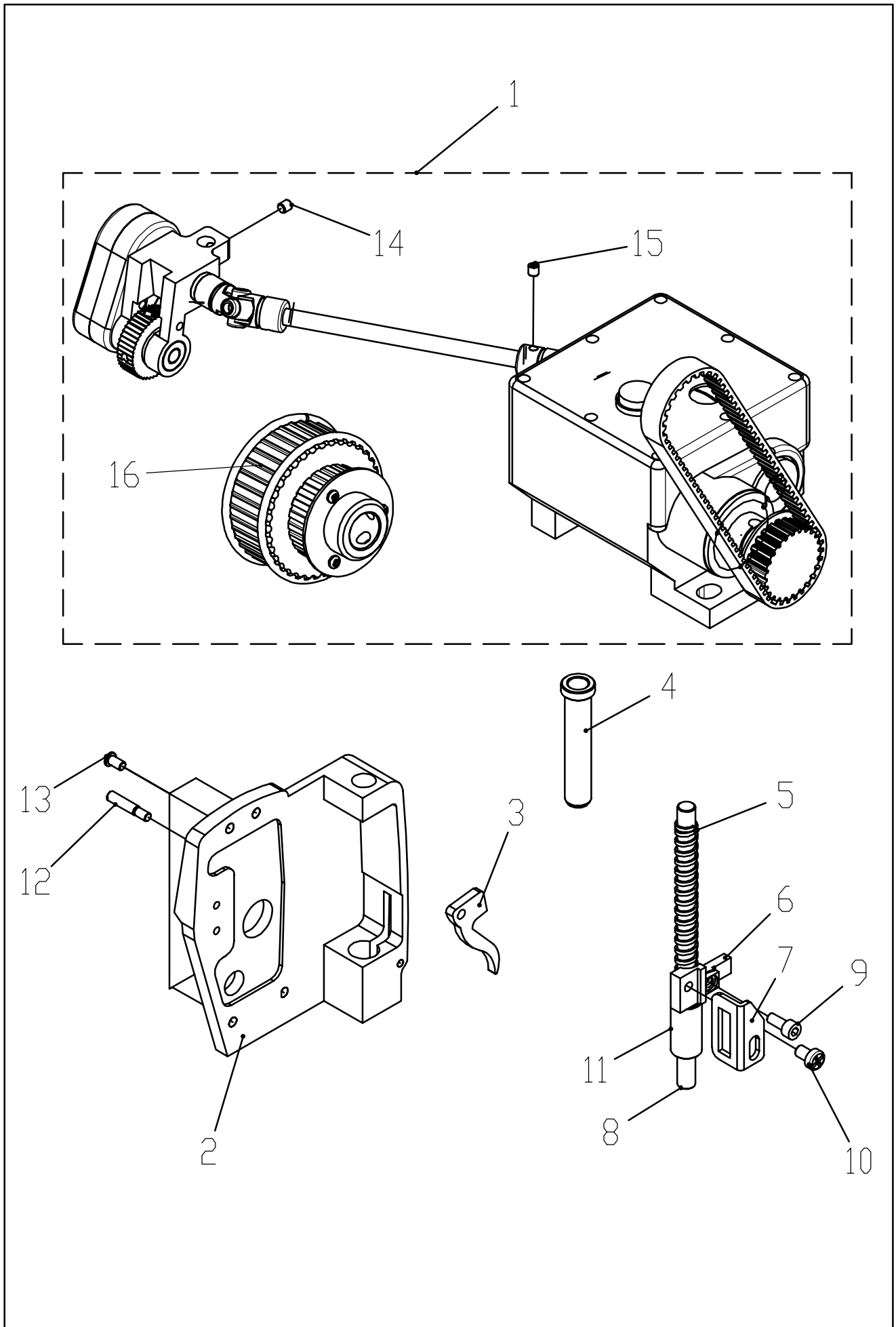

PS专用件/Special components for PS

序号 REF. NO.	件号 Part NO.	名称	Description	数量 Qty
1	4063100400	后拖轮组件	After the puller wheel device assm.	1
2	40601032	边盖	Top cover	1
3	40601031	扳手	Wrench	1
4	40603019	调压螺母	Voltage regulating screw	1
5	40627013	调压弹簧	Voltage regulating spring	1
6	40609009	调压杆夹	Voltage regulating rod clamp	1
7	40612047	连接片	connecting piece	1
8	40602016	拖轮轴	Presser foot rod	1
9	413S13019	螺钉	Screw	1
10	409S11013	螺钉	Screw	1
11	40603021	调压杆轴套	Voltage regulating rod shaft tube	1
12	40602013	扳手销	Wrench pin	1
13	406S11009	端面盖固定螺钉	Top cover set screw	4
14	409S14001	拖布轮支架螺钉	Puller bracket screw	1
15	406S12001	螺钉	Screw	8
16	4063500900	上轴步带轮组件	Timing belt wheel assy, upper	1

Z1、附件/Accessories

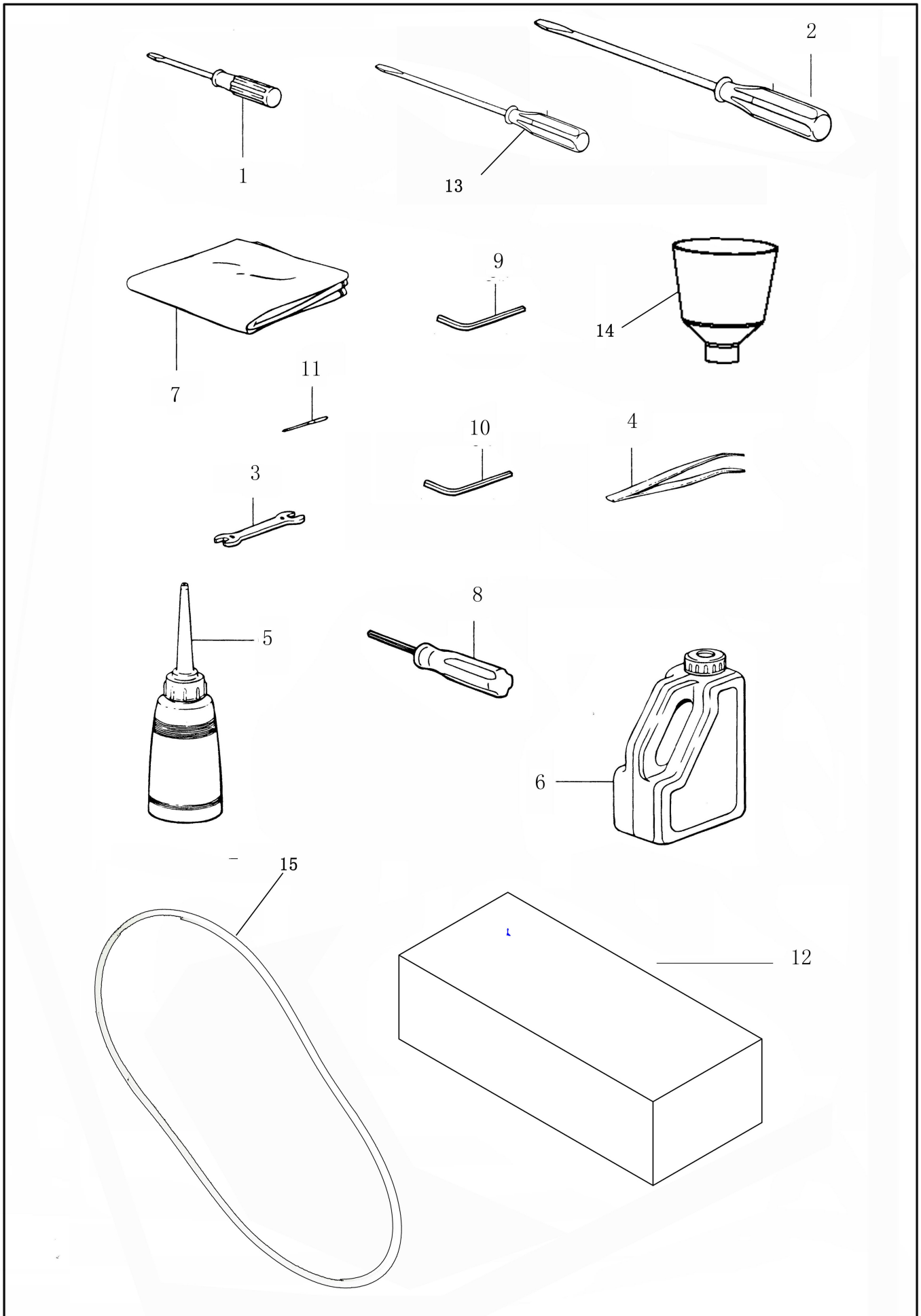

Z1、附件/Accessories

序号 REF. NO.	件号 Part NO.	名称	Description	数量 Qty
1	10131004	螺丝刀（小）	Screw driver (small)	1
2	10131002	螺丝刀（大）	Screw driver (big)	1
3	30131005	扳手（6mm~7mm）	Wrench, 6X7	1
4	20131080	镊子(JACK)	Pincette	1
5	20131038	小油壶（尖嘴）	Oiler assy	1
6	20131037	油壶	Oiler assy	1
7	40631003	机头罩	Head cover	1
8	20131042	内六角2	Screw driver, 2	1
9	30131010	内六角3	Screw driver, 3	1
10	30131012	内六角4	Screw driver, 4	1
11	40617001	机针	Needle 12#	4
12	2053102900	四线架组件	Cotton stand assy four	1
12	2053103100	六线架组件	Cotton stand assy six	1
13	10131003	螺丝刀（中）	Screw driver (middle)	1
14	20131039	漏斗	Funnel	1
15	10135002	传动带	The drive belt	1

不同型号的零件清单/Different parts list

序号 REF. NO	机型 MODEL	针位组代码 NEEDLES POSITION CODE	卷边器代码 BEADER CODE
1	JK-T9270-12(1/4)	4063401400	40615021
2	JK-T9270-12(3/16)	4063401500	40615022
3	JK-T9270-13(1/8)	4063402300	40615021
4	JK-T9270-12-2PL(1/4)	4063401400	40615021
5	JK-T9270-12-2PL(3/16)	4063401500	40615022
6	JK-T9270-13-2PL(1/8)	4063402300	40615021
7	JK-T9270-12-2PS(1/4)	4063401400	40615021
8	JK-T9270-12-2PS(3/16)	4063401500	40615022
9	JK-T9280-73-PL(1/8)	4063401600	4061503100
10	JK-T9280-73-2PL(1/8)	4063402000	4061503100
11	JK-T9280-73-PS(1/8)	4063401600	4061503100